

# CENG 3420

# Computer Organization & Design



## Lecture 05: Logic Basis

Bei Yu

CSE Department, CUHK

[byu@cse.cuhk.edu.hk](mailto:byu@cse.cuhk.edu.hk)

(Textbook: Chapter 2.4)

Spring 2023



① Numeral System

② Logic Gates (Optional)



# Numeral System



## Analog Signal

- Vary in a smooth way over time
- Analog data are continuous valued
  - Example: audio, video

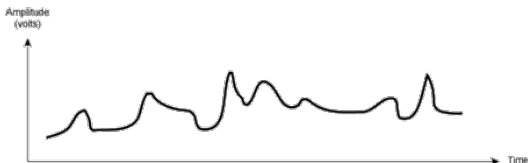

## Digital Signal

- Maintains a constant level then changes to another constant level (generally operate in one of the two states)
- Digital data are discrete valued
  - Example: computer data

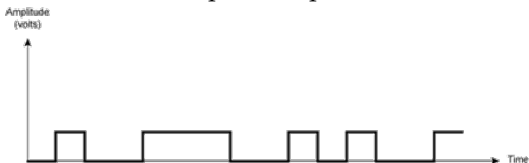



- An ordered set of symbols, called digits, with relations defined for addition, subtraction, multiplication, and division
- **Radix** or **base** of the number system is the total number of digits allowed in the number system
- Commonly used numeral systems

System Name	Decimal	Binary	Octal	Hexadecimal
Radix	10	2	8	16
First seventeen positive integers	0	0	0	0
	1	1	1	1
	2	10	2	2
	3	11	3	3
	4	100	4	4
	5	101	5	5
	6	110	6	6
	7	111	7	7
	8	1000	10	8
	9	1001	11	9
	10	1010	12	A
	11	1011	13	B
	12	1100	14	C
	13	1101	15	D
	14	1110	16	E
	15	1111	17	F
16	10000	20	10	

- In the 2009 film *Avatar*, Na'vi race employs an octal numeral system.





- Step 1: Divide the decimal number by the radix (number base)
- Step 2: Save the remainder (first remainder is the least significant digit)
- Repeat steps 1 and 2 until the quotient is zero
- Result is in reverse order of remainders



- EX1: Convert  $36_8$  to binary value
- EX2: Convert  $36_{10}$  to binary value



# Unsigned Binary Representation



Hex	Binary	Decimal
0x00000000	0...0000	0
0x00000001	0...0001	1
0x00000002	0...0010	2
0x00000003	0...0011	3
0x00000004	0...0100	4
0x00000005	0...0101	5
0x00000006	0...0110	6
0x00000007	0...0111	7
0x00000008	0...1000	8
0x00000009	0...1001	9
	...	
0xFFFFFFFF	1...1111	$2^{32} - 1$
0xFFFFFFFFC	1...1100	$2^{32} - 4$
0xFFFFFFFFD	1...1101	$2^{32} - 3$
0xFFFFFFFFE	1...1110	$2^{32} - 2$
0xFFFFFFFFF	1...1111	$2^{32} - 1$

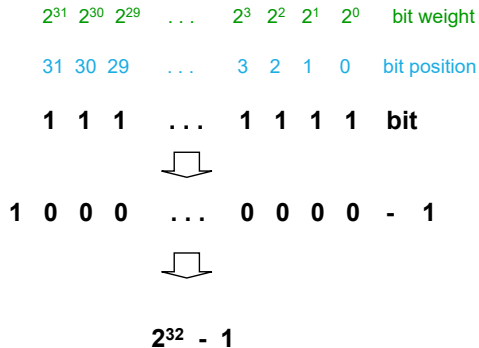

# Signed Binary Representation



	2'sc binary	decimal
$-2^3 =$	1000	-8
$-(2^3 - 1) =$	1001	-7
	1010	-6
	1011	-5
	1100	-4
	1101	-3
	1110	-2
	1111	-1
	0000	0
	0001	1
	0010	2
	0011	3
	0100	4
	0101	5
	0110	6
	0111	7

complement all the bits

0101      1011

and add a 1      and add a 1

0110      1010

complement all the bits

$2^3 - 1 =$



- For an  $n$ -bit signed binary numeral system, what's the largest positive number and the smallest negative number?



- Active HIGH
  - High voltage means On
- Active LOW
  - Low voltage means Off

Logic 0	Logic 1
False	True
Off	On
LOW	HIGH
No	Yes
Open switch	Closed switch

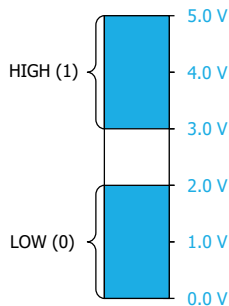



- Just like in grade school (carry/borrow 1s)

$$\begin{array}{r} 0111 \\ + 0110 \\ \hline \end{array} \qquad \begin{array}{r} 0111 \\ - 0110 \\ \hline \end{array} \qquad \begin{array}{r} 0110 \\ - 0101 \\ \hline \end{array}$$

- Two's complement operations are easy: do subtraction by negating and then adding

$$\begin{array}{r} 0111 \\ - 0110 \\ \hline \end{array} \quad \rightarrow \quad \begin{array}{r} 0111 \\ + 1010 \\ \hline \end{array}$$

- Overflow (result too large for finite computer word). E.g., adding two n-bit numbers does not yield an n-bit number

$$\begin{array}{r} 0111 \\ + 0001 \\ \hline \end{array}$$



# Logic Gates (Optional)

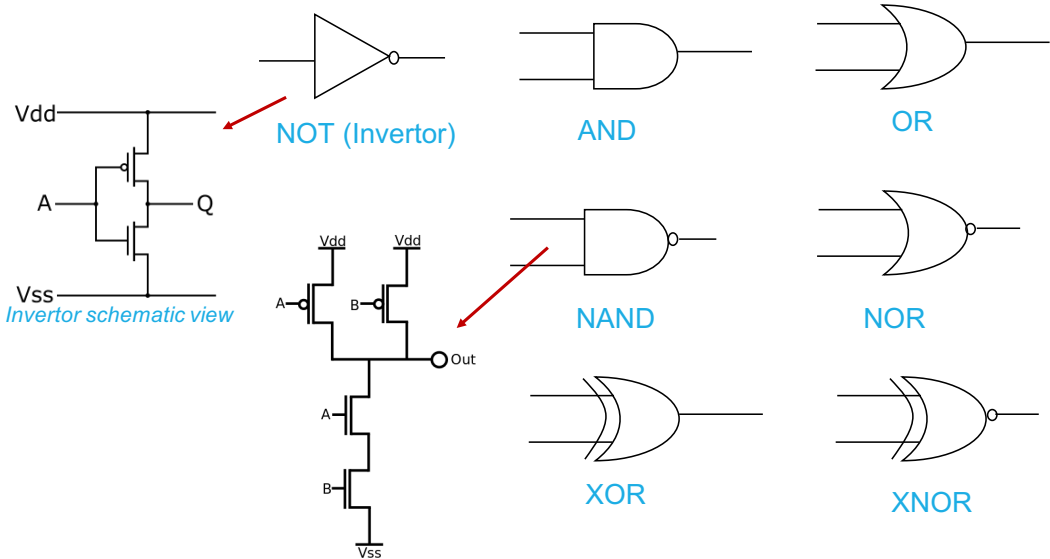

- What is the schematic view of an AND gate?



- Please draw NOR gate schematic view





- A means for describing how a logic circuit's output depends on the logic levels present at the circuit's inputs
- The number of input combinations will equal  $2^N$  for an N-input truth table

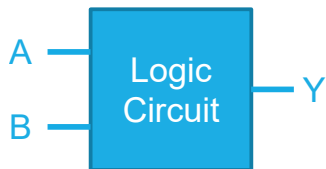

Inputs		Output
A	B	Y
0	0	0
0	1	0
1	0	0
1	1	1



- Determine the true table of a three-input AND gate