

Lab5 Sound Recorder

Qi SUN

Outline

- Hardware system
- Software
- Requirements

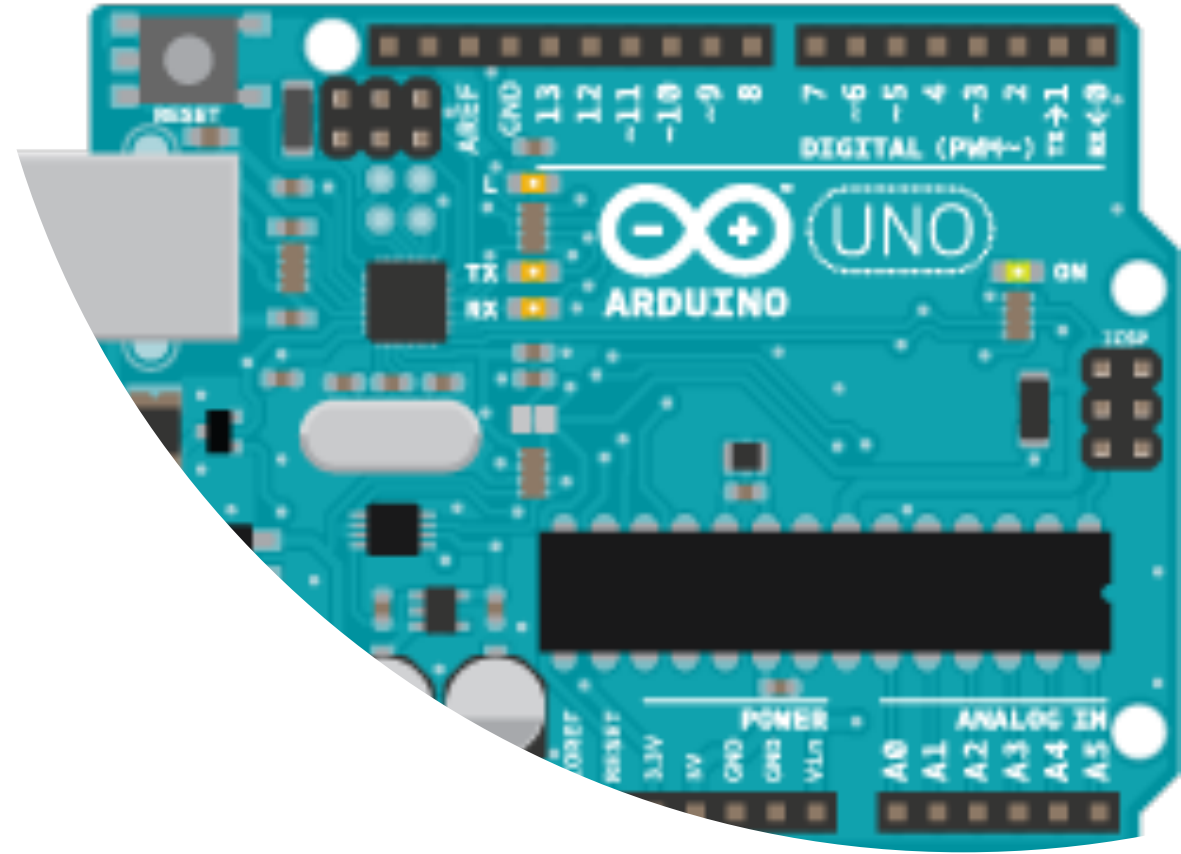

Hardware system

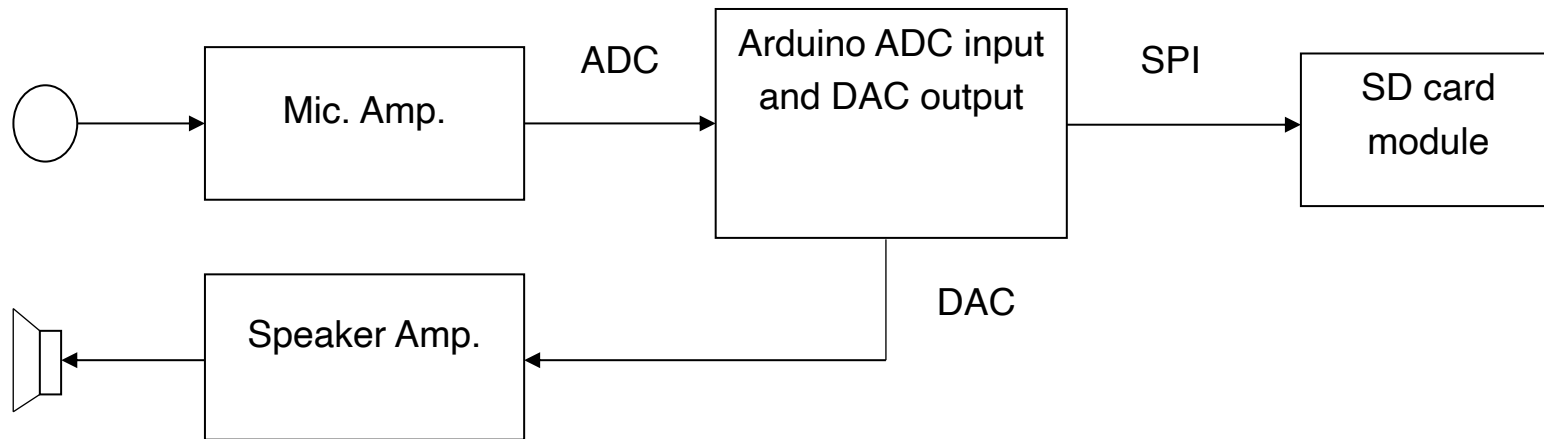

Software: Arduino TMRpcm library¹

- 1. TMRpcm audio;** // create an object for use like recording and playing the audio signal.
- 2. audio.startRecording(<Song Name>,<Sample Rate>, <analog pin>);**
audio.startRecording(<Song Name>,<Sample Rate>, <analog pin>,
<passthrough mode>); // Starts recording from the specified analog pin
- 3. audio.stopRecording(<Song Name>);** // Stops the recording and finalizes the wav file
- 4. audio.play(<Song Name>);** // Play a file on output
- 5. audio.stopPlayback();** // stop playback

1. TMRpcm library wiki : <https://github.com/TMRh20/TMRpcm/wiki>

Software: Sampling Rate

According to Nyquist sampling theorem, the sampling frequency $f_{sampling}$ should be greater or equal to two times f_{max} .

$$f_{sampling} \geq 2 \times f_{max}$$

In our example, we assume the $f_{max} = 8\text{KHz}$ (e.g. the highest note of a piano is C8=4186Hz), so we choose the sampling frequency $f_{sampling} = 16\text{ KHz}$.

Software: RealTerm terminal

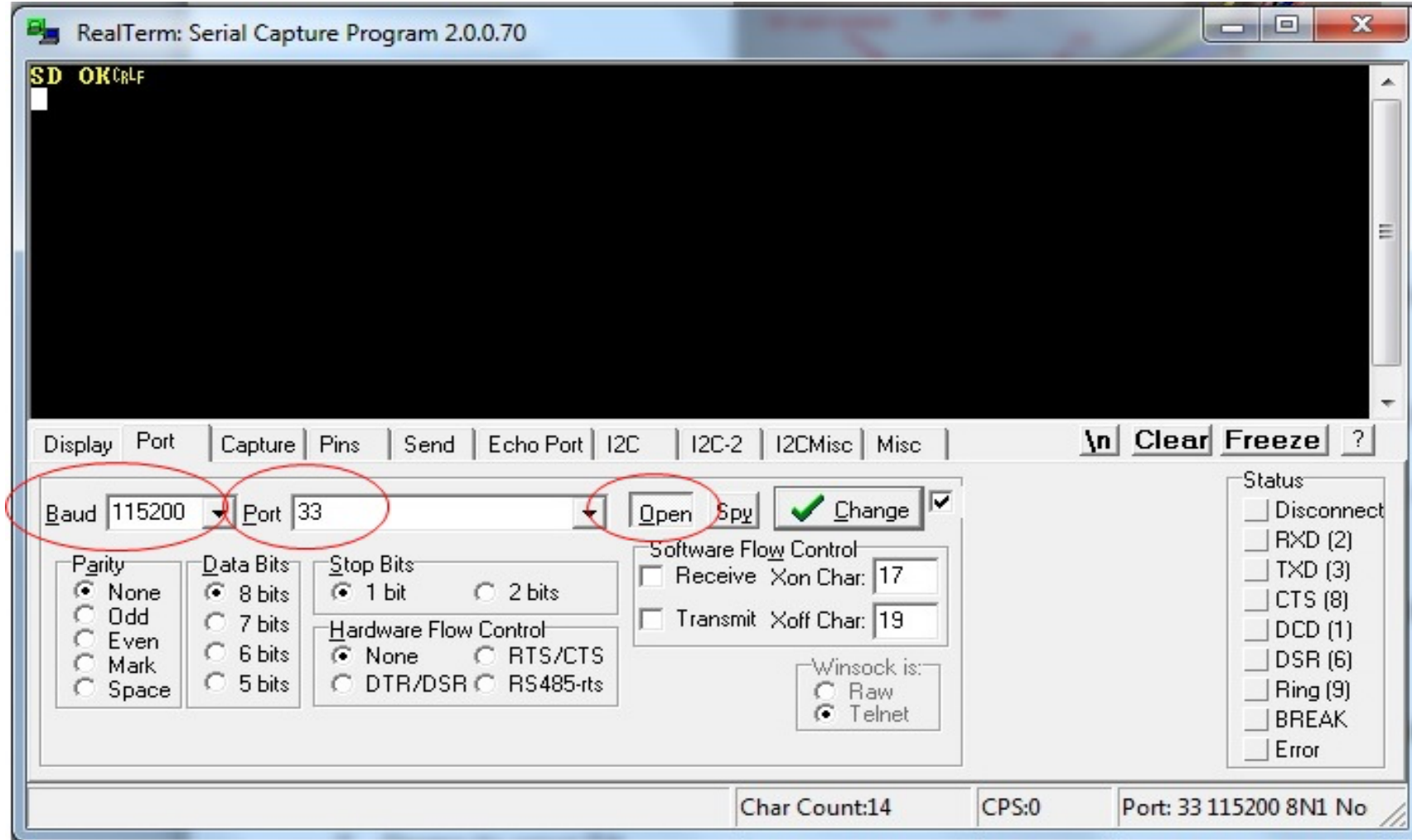

Requirements

- 1. Record a demo of playing your audio recorder;**
- 2. Answer the questions on the Lab 5 Questions page;**
- 3. You are required to submit both demo and answers to blackboard before deadline.**