



CENG4480

Lecture 02: Operational Amplifier – 1

Bei Yu

byu@cse.cuhk.edu.hk

(Latest update: August 19, 2020)

Fall 2020



香港中文大學

The Chinese University of Hong Kong

Overview



Introduction

Op-Amp Preliminaries

Op-Amp List

Overview



Introduction

Op-Amp Preliminaries

Op-Amp List



To Learn:

- ▶ how to connect the computer to various physical devices.
- ▶ Overall interfacing schemes
- ▶ Analog interface circuits, active filters

Some diagrams are taken from references:

- ▶ [1] S.E. Derenzo, "*Interfacing– A laboratory approach using the microcomputer for instrumentation, data analysis and control*", Prentice Hall, 1990.
- ▶ [2] Giorgio Rizzoni, "*Principles and Applications of Electrical Engineering*", McGraw-Hill, 2005.

Amplifier in Audio System

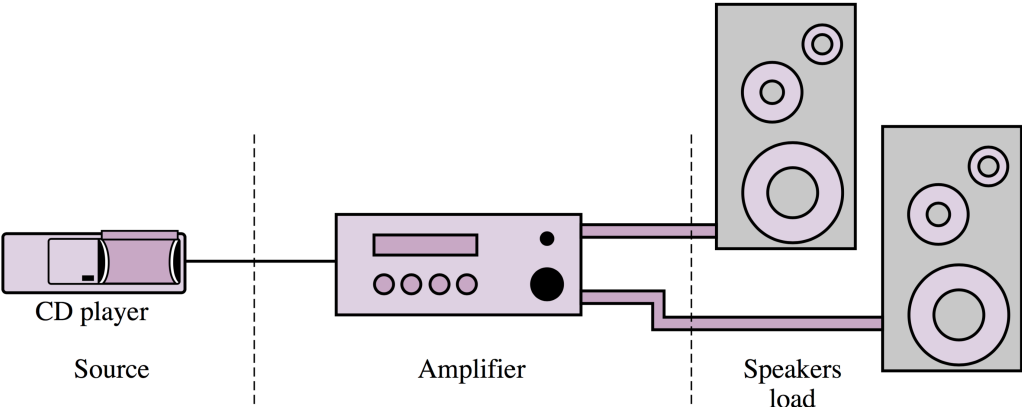

Converting low-voltage sensor signal to a level suitable for driving speakers.

Typical Data Acquisition and Control System

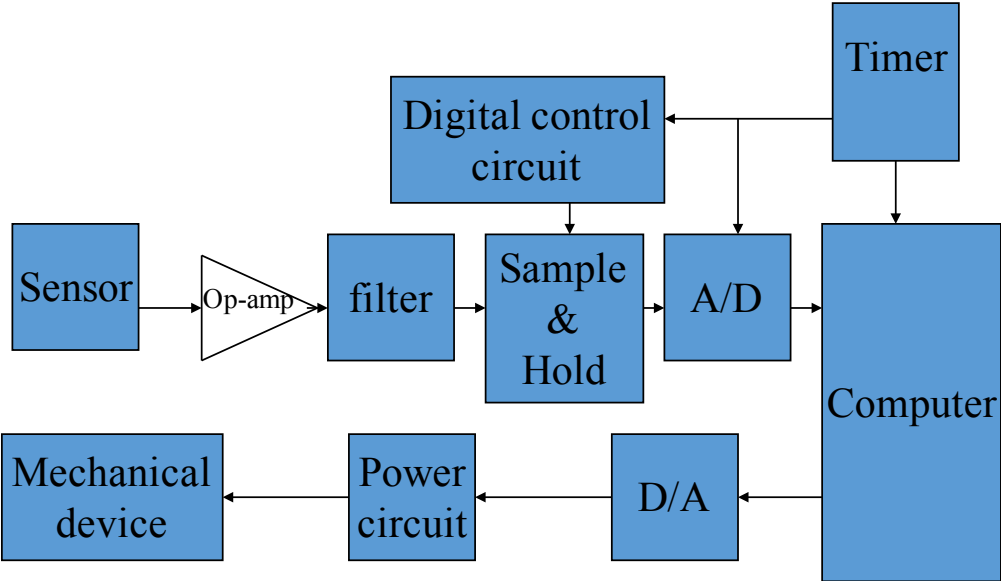

Analog Interface Example 1



Audio recording systems

- ▶ Audio recording systems
- ▶ Audio signal is 20–20KHz
- ▶ Sampling at 40KHz, 16-bit is Hi-Fi
- ▶ Stereo ADC requires to sample at 80KHz.
- ▶ Calculate storage requirement for one hour?
- ▶ Audio recording standards: Audio CD; Mini-disk MD; MP3

Analog Interface Example 2



Analog hand held controller



(a) PS5



(b) Wii



(c) Driving wheel

Operational Amplifier (Op-Amp)



- ▶ Why use op amp?
- ▶ What kinds of inputs/outputs do you want?
- ▶ What frequency responses do you want?

Direct Current (DC) amplifier



- ▶ **Example:** use power op amp (or transistor) to control the DC motor operation.
- ▶ Need to maintain the output voltage at a certain level for a long time.
- ▶ All DC (biased) levels must be designed accurately .
- ▶ Circuit design is more difficult.

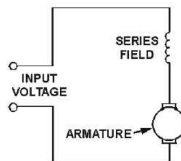
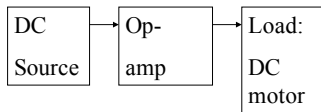



Biasing in electronics

The method of establishing predetermined voltages or currents at various points of an electronic circuit for the purpose of establishing proper operating conditions in electronic components

<https://en.wikipedia.org/wiki/Biasing>

Alternating Current (AC) amplifier



- ▶ **Example:** Microphone amplifier, signal is AC and is changing at a certain frequency range.
- ▶ Current is alternating not stable.
- ▶ Use capacitors to connect different stages
- ▶ So no need to consider biasing problems.

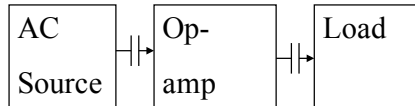

Overview



Introduction

Op-Amp Preliminaries

Op-Amp List



Amplifier

A circuit where the output signal power is greater than the input signal power.

Otherwise is referred as an **attenuator**.

Black-Box to Consider Circuit Effect

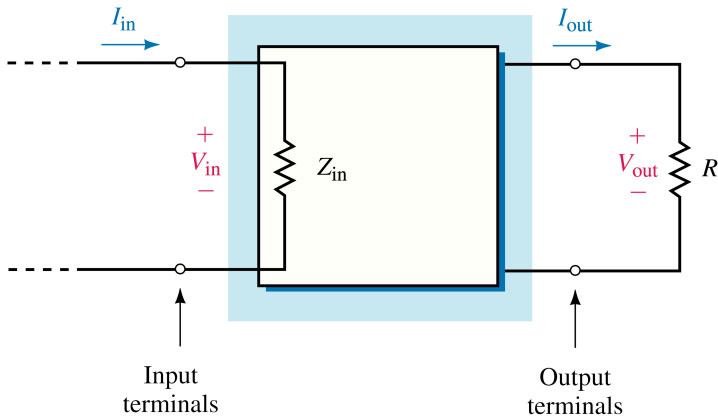

- ▶ Without examining actual operation (thousands of elements)
- ▶ Z_{in} : input impedance (a.k.a. R_{in})



Voltage gain A

$$A = \frac{V_{out}}{V_{in}}$$

- ▶ Usually voltage gain may be either very large or very small
- ▶ Inconvenient to express as a simple ratio
- ▶ Therefore, **decibel** (dB):

Voltage gain in **dB**

$$A = 20 \cdot \log_{10} \frac{V_{out}}{V_{in}}$$



Question: Voltage Gain

$V_{in} = 20\text{mV}$, $V_{out} = 500\text{mV}$. Calculate the voltage gain in dB.

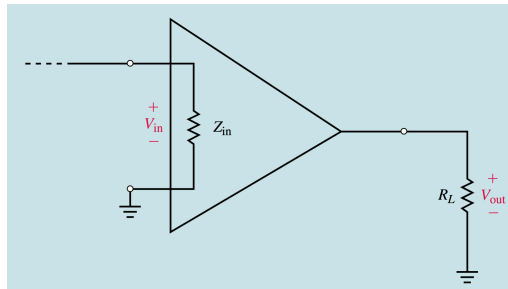

Operational amplifier circuit diagram

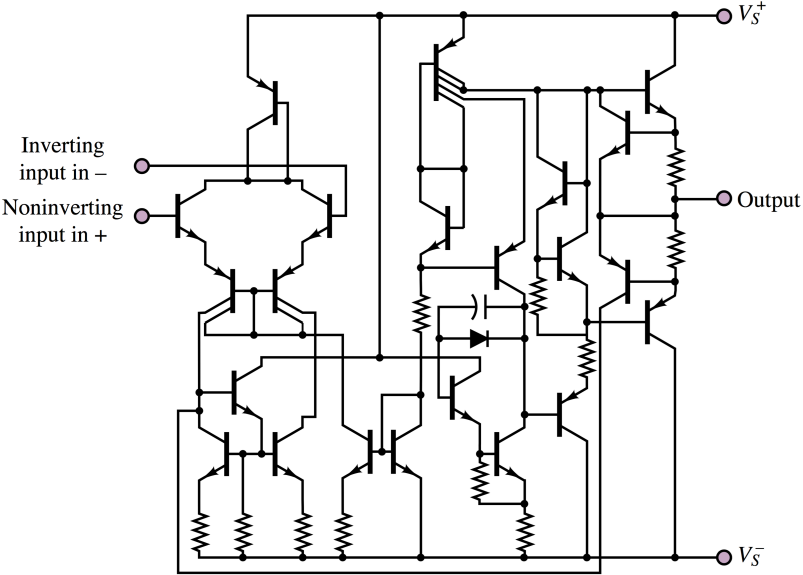

Simplified circuit symbol

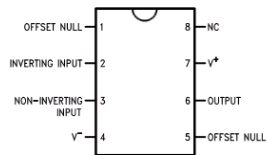
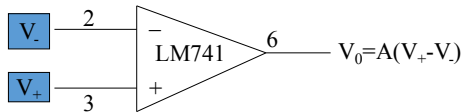

Order Number LM741J, LM741J/883,

- ▶ **Ideal** difference amplifier
- ▶ (+): **noninverting input**
- ▶ (-): **inverting input**
- ▶ **A**: **open-loop voltage gain** (order of 10^5 to 10^7)

R_{in} & R_{out}

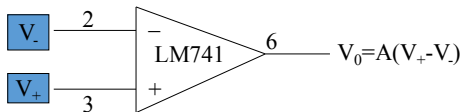

- ▶ R_{in} : input impedance (**High**)
- ▶ R_{out} : output impedance (**Low**)

Why prefer High R_{in} , Low R_{out} ?

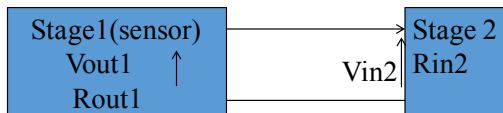

Is equivalent to:

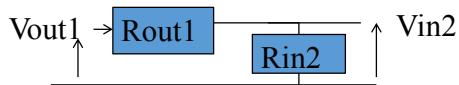

Why prefer High R_{in} , Low R_{out} ?

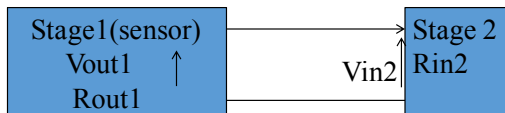

Is equivalent to:

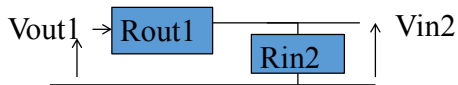

To maximize V_{in2}

$$V_{in2} = V_{out1} \cdot \frac{R_{in2}}{R_{out1} + R_{in2}}$$

Open-loop & Closed-loop



- ▶ Open-loop gain
- ▶ Closed-loop gain

Feedback connection

The effect of the feedback connection from output to **inverting input** is to force the voltage at the inverting input to be equal to that at the noninverting input.

“Note that closing the feedback loop turns a generally **useless** amplifier (the gain is too high!) into a very **useful** one (the gain is just right!)”

Ideal Op-Amp Rules



Rule 1

No current flows in or out of the inputs

Rule 2

The Op-Amp tries to keep the inputs the **same** voltage

* Rule 2 is only for negative feedback op-amp

Ideal Op-Amp v.s. Real Op-Amp



Open-Loop Gain A

Ideal: Infinite, thus $V^+ = V^-$

Real: Typical range (20,000, 200,000), thus $V_{out} = A(V^+ - V^-)$

Input Impedance

Ideal: Infinite. Since $Z_{in} = \frac{V_{in}}{I_{in}}$, zero input current

Real: No such rule.

Bandwidth

Ideal: Infinite Bandwidth

Real: Gain-Bandwidth product (GB).

Gain-Bandwidth Product

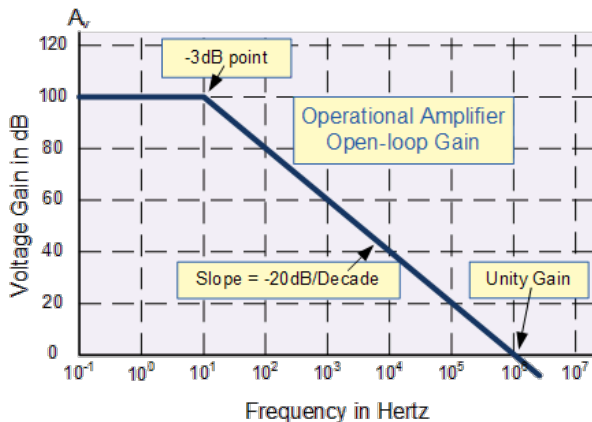

- ▶ Fixed gain-bandwidth product for any given amplifier
- ▶ Define bandwidth as the frequency range over which the voltage gain of the amplifier is above 70.7% or **-3dB** of its maximum output value



Slew Rate

$$\text{Slew rate} = \left| \frac{dv(t)}{dt} \right|$$

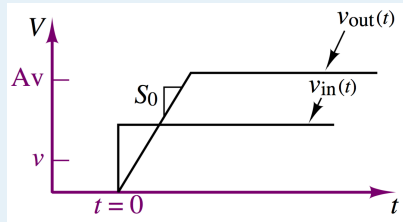

Overview



Introduction

Op-Amp Preliminaries

Op-Amp List

Voltage follower

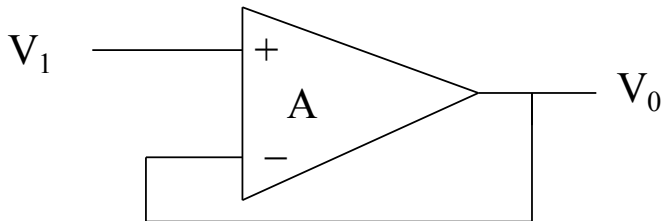

- ▶ Unit voltage gain
- ▶ Output $V_0 = V_1$
- ▶ high current gain, high input impedance

In real op-amp

$$V_0 = A(V_1 - V_0) \Rightarrow V_0 = \frac{V_1 A}{1 + A} \approx V_1$$



Non-inverting Amplifier

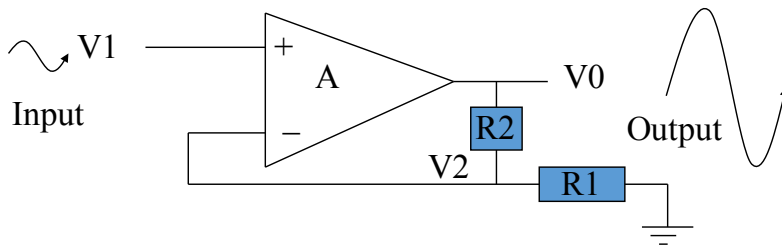

- ▶ R_{in} : High input impedance

In real op-amp

$$V_0 = A(V_1 - V_2) \text{ and } \frac{V_2}{V_0} = \frac{R_1}{R_1 + R_2}$$
$$\Rightarrow \frac{V_0}{V_1} = \frac{R_1 + R_2}{R_1 + (R_1 + R_2)/A} \approx \frac{R_1 + R_2}{R_1}$$



Question: Non-inverting Amplifier Gain

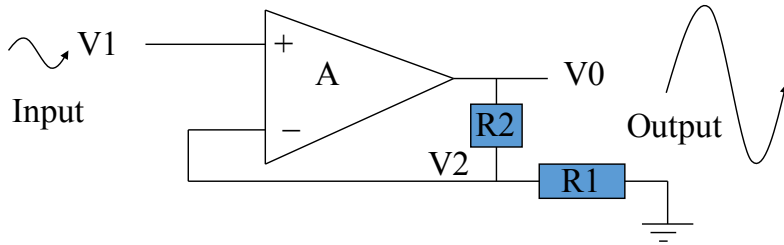

Calculate $\frac{V_0}{V_1} =$

Current to Voltage Converter

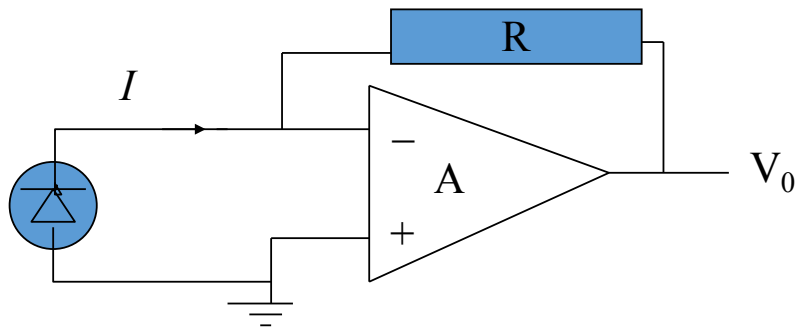

$$V_0 = -I \cdot R$$

Inverting Amplifier

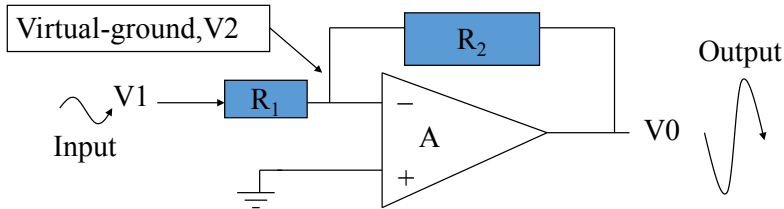

Because of Kirchhoff's circuit laws, $i_1 + i_2 = i^- = 0$

In real op-amp

$$V_0 = A(0 - V_2) \text{ and } \frac{V_2 - V_1}{R_1} = \frac{V_0 - V_2}{R_2}$$
$$\Rightarrow R_1\left(V_0 + \frac{V_0}{A}\right) = -R_2\left(\frac{V_0}{A} + V_1\right) \Rightarrow \frac{V_0}{V_1} \approx -\frac{R_2}{R_1}$$

Inverting Amplifier

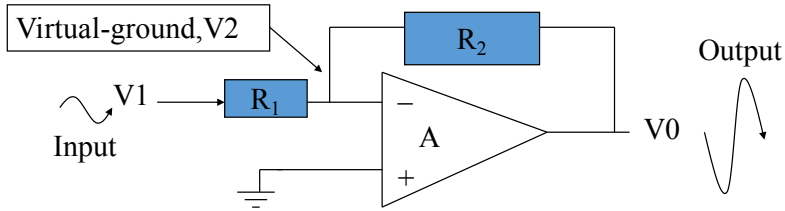

- ▶ $R_{in} = R_1$
- ▶ Gain (G) = $-\frac{R_2}{R_1}$

Inverting Amplifier

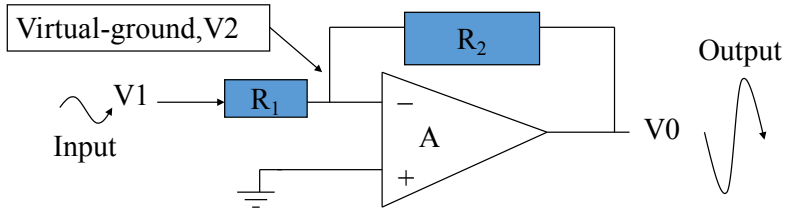

- ▶ $R_{in} = R_1$
- ▶ Gain (G) = $-\frac{R_2}{R_1}$

Question: How to increase input impedance?

Summing Amplifier

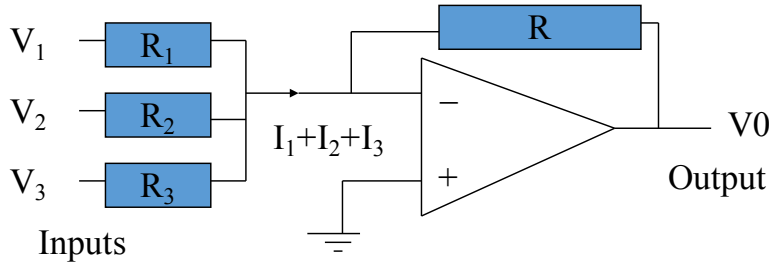

$$V_0 = -R \cdot \left\{ \frac{V_1}{R_1} + \frac{V_2}{R_2} + \frac{V_3}{R_3} \right\}$$

Differential Amplifier

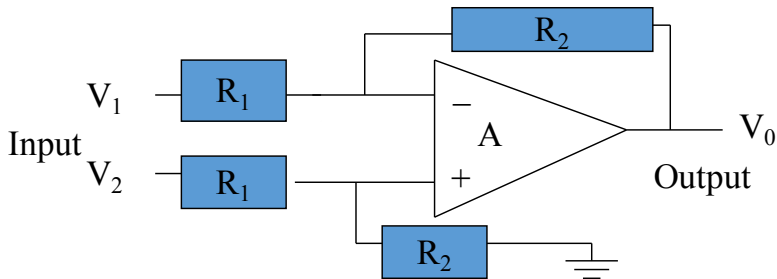

- ▶ Calculate the difference between V_1 and V_2
- ▶ Can control gain



Question: Differential Amplifier Gain

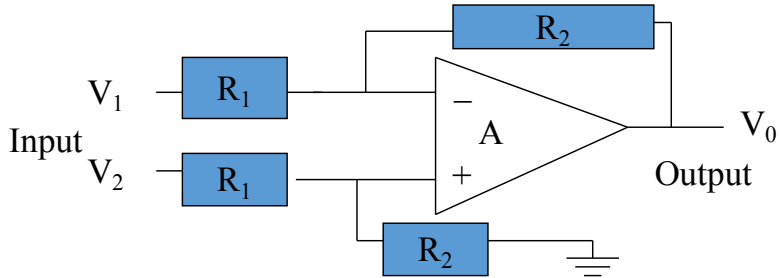

Calculate $V_0 =$



Question: Differential Amplifier Gain

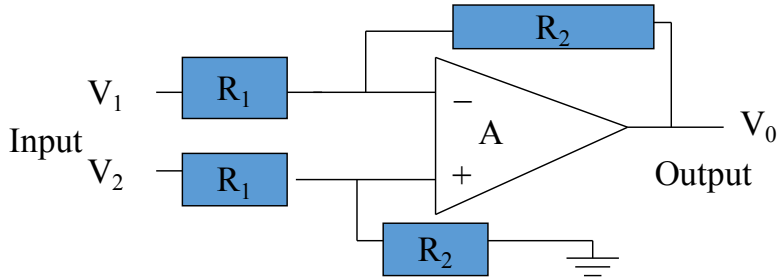

Calculate $V_0 =$

Instrumental Amplifier

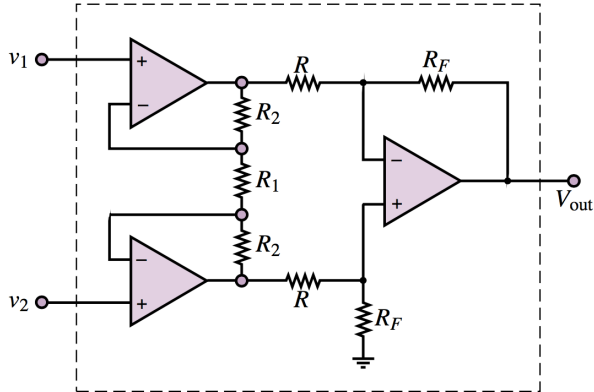

- ▶ To make a **better** DC amplifier from op-amps
- ▶ combine **2** noninverting amplifier & **1** differential amplifier

Instrumental Amplifier (cont.)

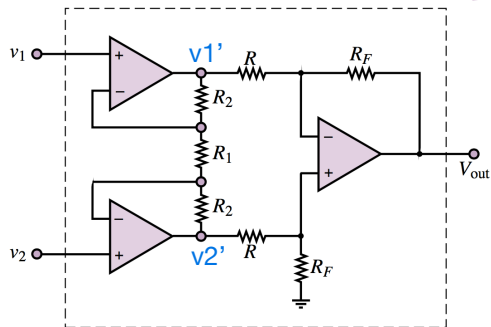

Solution 1:

- ▶ For each non-inverting amplifier: $A = 1 + \frac{2R_2}{R_1}$
- ▶ Connecting to differential amplifier:

$$\begin{aligned} V_{out} &= \frac{R_F}{R}(v_2' - v_1') \\ &= \frac{R_F}{R}\left(1 + \frac{2R_2}{R_1}\right)(v_2 - v_1) \end{aligned}$$

Instrumental Amplifier (cont.)

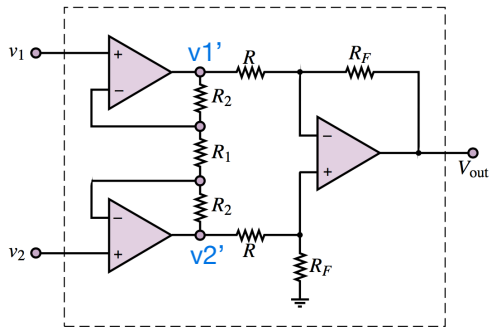

Solution 2:

- ▶ By rule 2, two input voltages are the same, thus

$$\frac{v_2 - v_1}{R} = \frac{v_2' - v_1'}{2R_1 + R}$$

- ▶ Therefore: $v_2' - v_1' = \left(1 + \frac{2R_1}{R}\right)(v_2 - v_1)$

Comparing Amplifiers



	Op Amp	Inv. Amp	Noninv. Amp	Diff. Amp	Instr. Amp
High R_{in}	✓	X	✓	X	✓
Diff Input	✓	X	X	✓	✓
Define Gain	X	✓	✓	✓	✓