

CENG4480 Embedded System Development and Applications

Computer Science and Engineering Department

The Chinese University of Hong Kong

Laboratory 6: A self-balancing platform

November 2021

Introduction

In this exercise you will learn how to develop a self-balancing platform and use the MPU6050 (GY-521) IMU module as a 2-axis tilt sensor. The MPU6050 contains a digital motion processor (DMP) which performs accelerator and gyro data fusion on the IMU chip itself. Your task is to implement the PID controller on Arduino Nano and control 2 servo motors to maintain the platform in the balancing state. The whole system setup picture is shown in Figure 1. The block diagram of the whole system is shown in Figure 2. You can refer to your lecture [1] CENG4480 Lecture 06: PID control for the principle of PID controller.

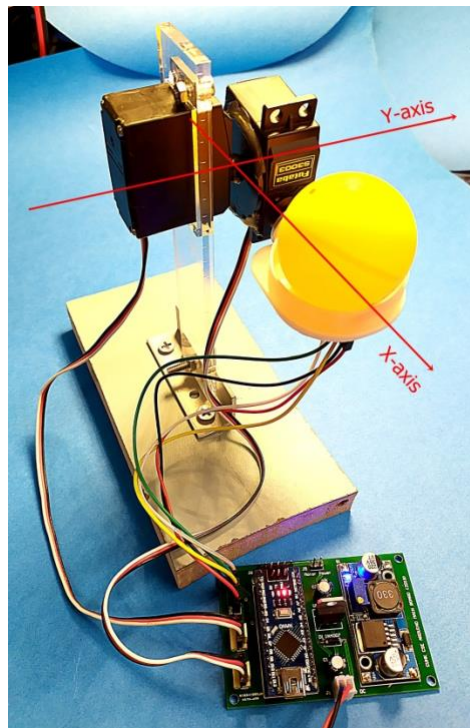

Figure 1. The experimental setup: the self-balancing platform holding a ball can be rotated in 2 axes

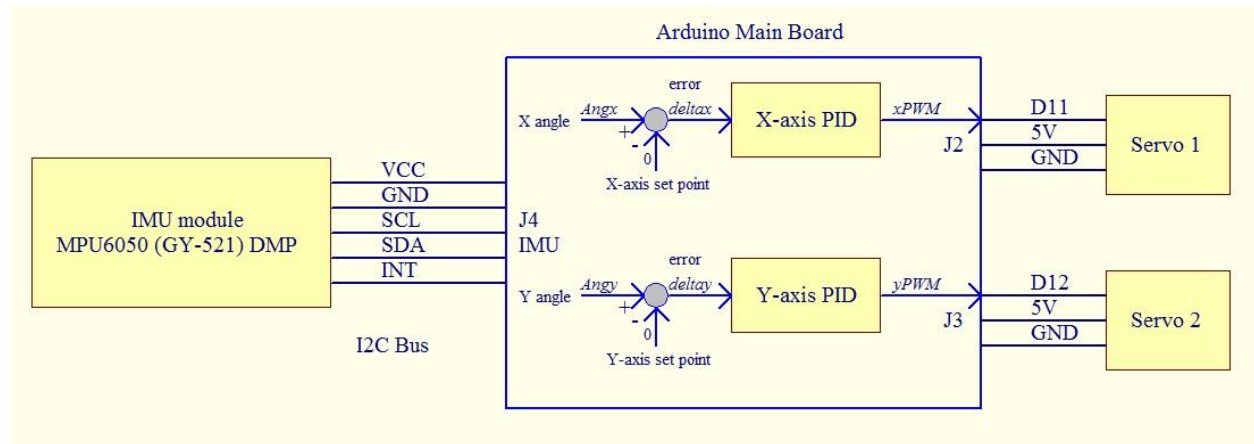

Figure 2. Block Diagram of Self-balancing Platform

Objectives

- To learn how to implement PID controller on embedded system
- To learn how to use MPU6050 (GY-521) IMU module Digital Motion Processing data to measure the tilt angles

Procedures

The procedures of the development are as follows:

1. Connect MPU6050 (GY-521) IMU module to Arduino main board

- Connect RED wire to VCC on IMU and to J4 pin 1 on Arduino main board
- Connect BLACK wire to GND on IMU and to J4 pin 2 on Arduino main board
- Connect YELLOW wire to SCL on IMU and to J4 pin 3 on Arduino main board
- Connect GREEN wire to SDA on IMU and to J4 pin 4 on Arduino main board
- Connect WHITE wire to INT on IMU and to J4 pin 5 on Arduino main board

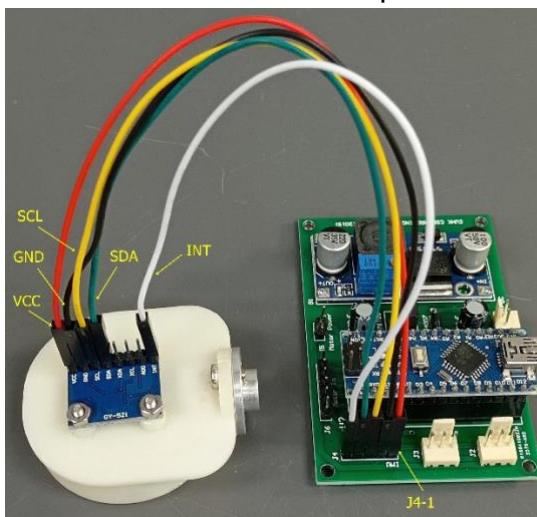

2. Connect 2 servo motors to the Arduino main board

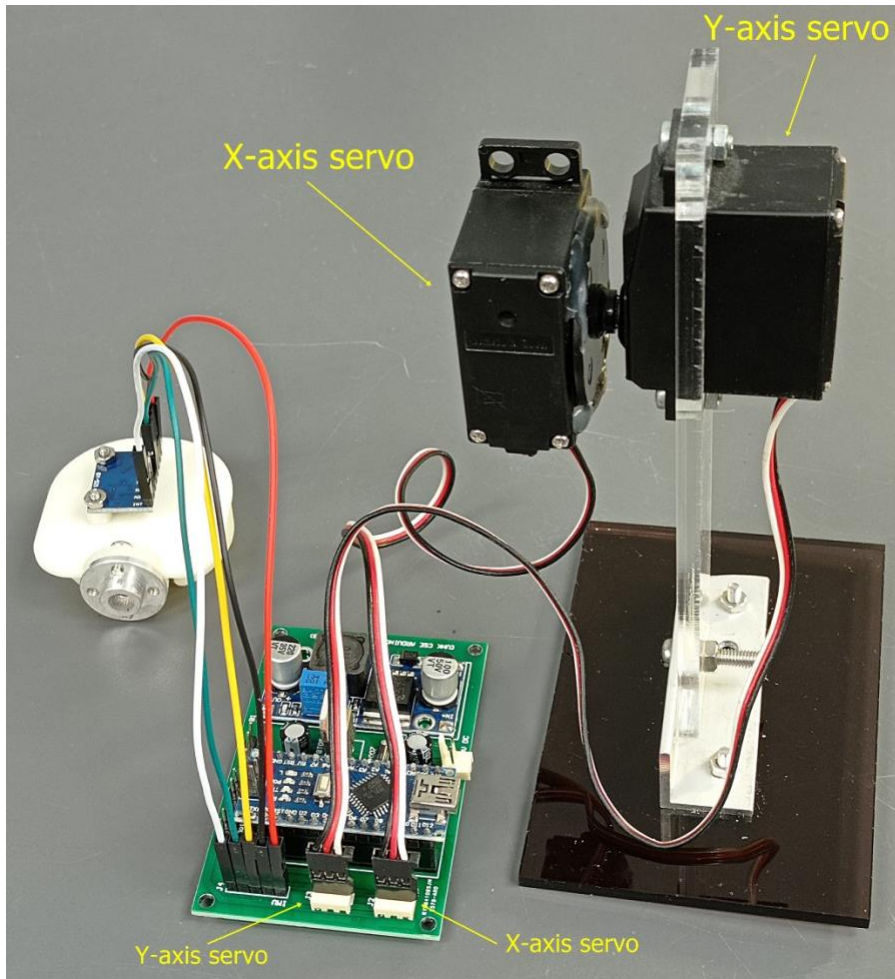

3. Attach the platform with IMU on the X-axis servo

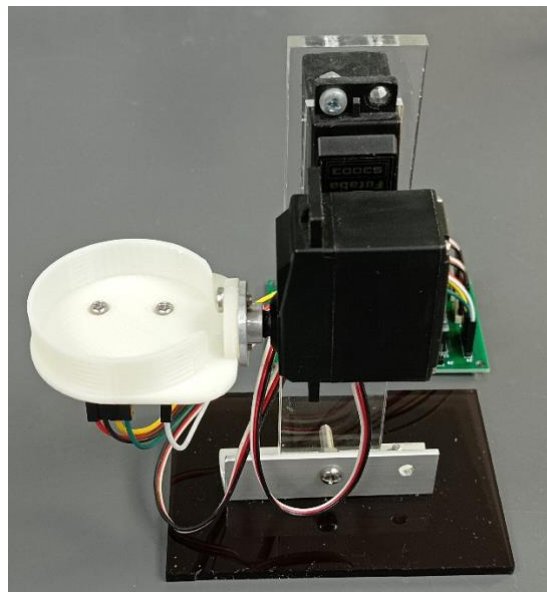

- The platform should be able to rotate 180 degree from left hand side to right hand side

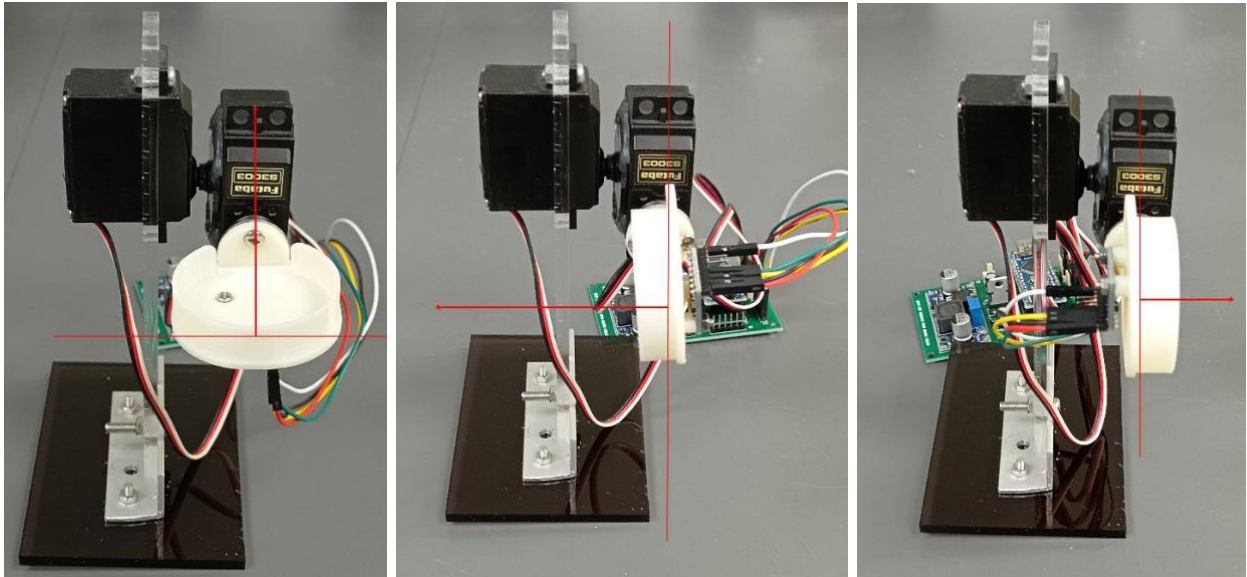

4. Download the Lab6_given.ino to Arduino
5. Write the Y-axis PID codes in the Lab6_given.ino to complete the system. (X-axis PID is provided in Lab6_given.ino)
6. Fine tune the PID controller constants to reach its optimal state.

You are required to move the platform without dropping the ball from -60 to 60 degrees against the X-axis and Y-axis as fast as you can.

Submit the codes and demo video to blackboard before 11:59 pm on November 25, 2021

END

References:

[1] CENG4480 Lecture 06: PID control –
<http://www.cse.cuhk.edu.hk/~byu/CENG4480/2021Fall/slides/Lec06-PID.pdf>