



CENG4480

Lecture 04: Analog/Digital Conversions

Bei Yu

byu@cse.cuhk.edu.hk

(Latest update: October 3, 2018)

Fall 2018



香港中文大學

The Chinese University of Hong Kong

Overview

Preliminaries

Comparator

Digital to Analog Conversion (DAC)

Analog to Digital Conversion (ADC)



Overview

Preliminaries

Comparator

Digital to Analog Conversion (DAC)

Analog to Digital Conversion (ADC)



Analog/Digital Conversions

Topics:

- ▶ Digital to analog conversion
- ▶ Analog to digital conversion
- ▶ Sampling-speed limitation
- ▶ Frequency aliasing
- ▶ Practical ADCs of different speed



Block Diagrams

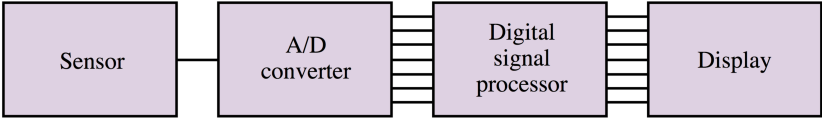

Digital measuring instrument

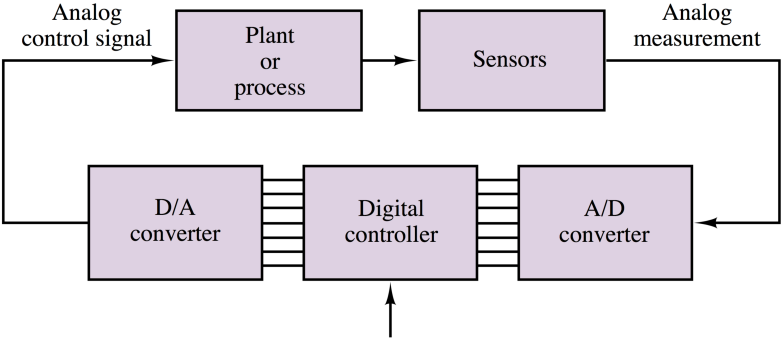

Digital control system



Overview

Preliminaries

Comparator

Digital to Analog Conversion (DAC)

Analog to Digital Conversion (ADC)



Op-Amp Comparator

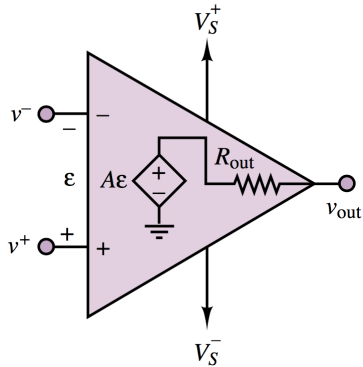

Open-Loop Mode

$$v_{out} = A_V(v^+ - v^-)$$

- ▶ Extreme large gain
- ▶ Any small difference ϵ will cause large outputs.



Voltage Supply Limits

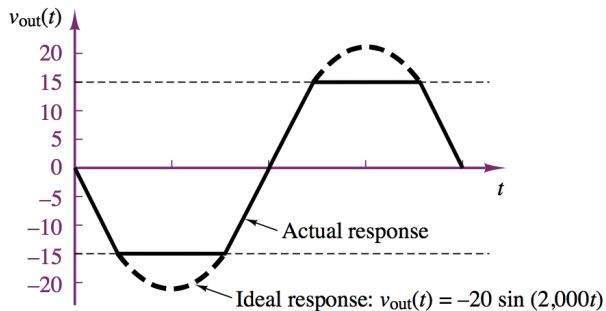

Op-amp output with voltage supply limit ($V_S^+ = V_S^- = 15$)

- ▶ Powered by external DC voltage supplies V_S^+ & V_S^-
- ▶ Amplifying signals **only** within the range of supply voltages
- ▶ In a practical op-amp, **saturation** would be reached at 1.5 V below the supply voltages.



Switching waveforms by Comparator

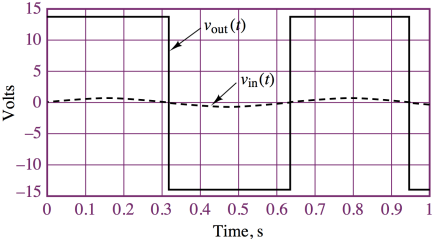
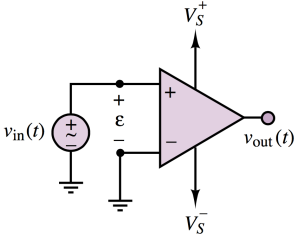

Switching waveforms of non-inverting comparator.

Since $\epsilon = V\cos(\omega t)$, therefore

$$\begin{aligned} \epsilon > 0 &\Rightarrow v_{out} = V_{sat}^+ \\ \epsilon < 0 &\Rightarrow v_{out} = V_{sat}^- \end{aligned}$$

* V_{sat} : saturation voltage (e.g., ± 15 V supplies is approximately ± 13.5 V)



Noninverting & Inverting Comparator

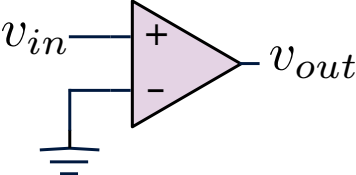

(a) Noninverting comparator

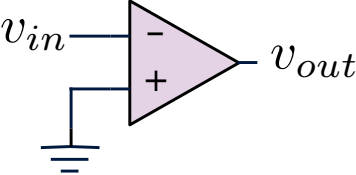

(b) Inverting comparator



Limitation of Conventional Comparator

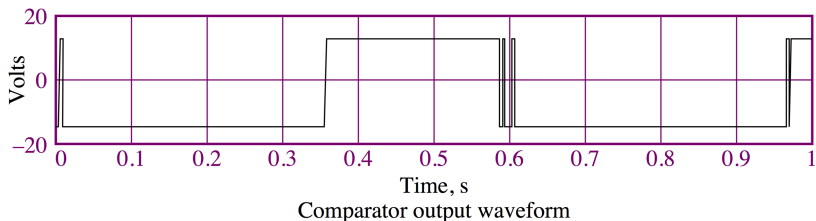
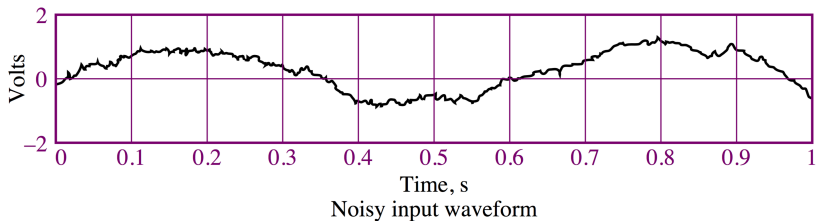

- ▶ In the presence of noisy inputs
- ▶ Cross the reference voltage level repeatedly
- ▶ Cause multiple triggering



Schmitt Trigger

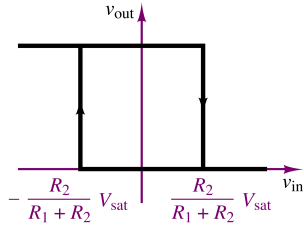
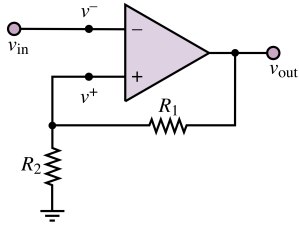

- ▶ Based on **Inverting** comparator
- ▶ Positive feedback
- ▶ (+) Increase the switching speed
- ▶ (+) Noise immunity



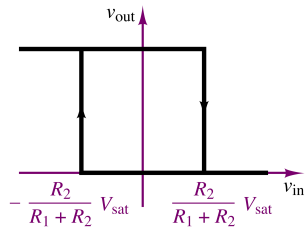
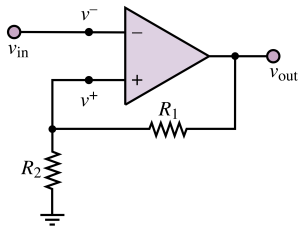

Question: prove two reference voltages of schmitt trigger.



Sample-and-Hold Amplifier

Motivations:

When a slow ADC is used to sample a fast changing signal only a short sampling point can be analyzed

- ▶ To resolve uncertainty during ADC
- ▶ “freeze” the value of analog waveform for a time sufficient for the ADC to complete its task



Sample-and-Hold Amplifier

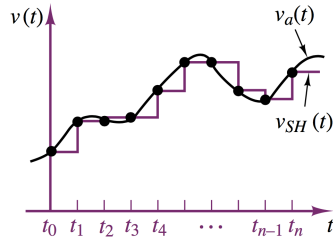
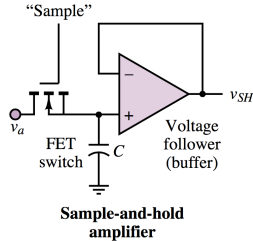

- ▶ A MOSFET analog switch is used to “sample” analog waveform
- ▶ While MOSFET conducts, charge the “hold” capacitor



Good Sample, Bad Sample

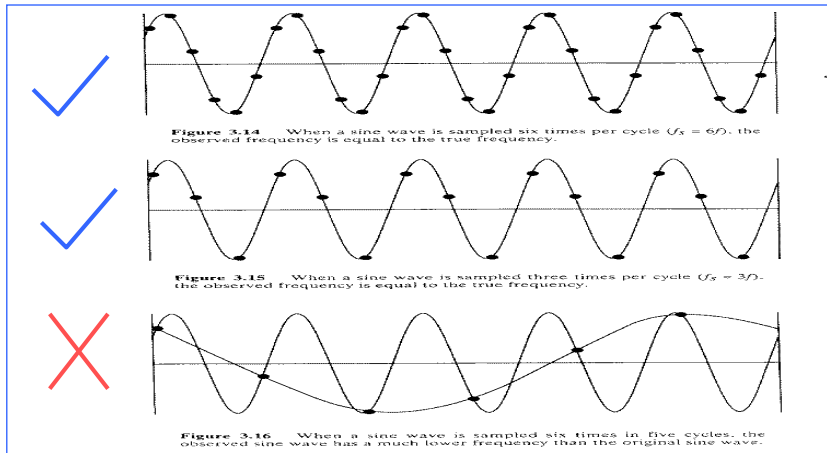

- ▶ When sampling 6 times per cycle, close to the original.
- ▶ when sampling 3 times per cycle, less reliable but frequency is equal to original.
- ▶ When sampling 6 times per 5 cycles, frequency is different.



Overview

Preliminaries

Comparator

Digital to Analog Conversion (DAC)

Analog to Digital Conversion (ADC)



Digital-to-Analog Converter (DAC)

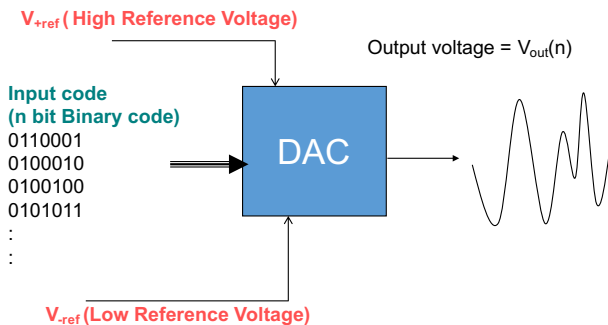

$$\begin{aligned}V_{out} &= (b_3b_2b_1b_0)_2 \\ &= (b_3 \cdot 2^3 + b_2 \cdot 2^2 + b_1 \cdot 2^1 + b_0 \cdot 2^0)_{10} \\ &= (8b_3 + 4b_2 + 2b_1 + b_0)\Delta v + V_{-ref}\end{aligned}$$

Δv : smallest step size by which voltage can increase



How to Determine Δv ?

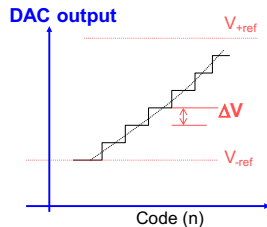
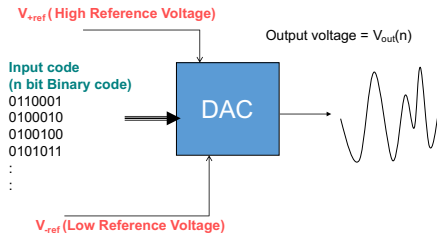

$$\Delta v = \frac{V_{+ref} - V_{-ref}}{2^n},$$

where n is the bit# of input digital signal.



DAC Characteristics

Glitch:

A transient spike in the output of a DAC that occurs when more than one bit changes in the input code.

- ▶ Use a low pass filter to reduce the glitch
- ▶ Use **sample-and-hold** circuit to reduce the glitch

Settling time:

Time for the output to settle to typically $1/4$ LSB after a change in DA output.



DAC Type 1: Weighted Adder DAC

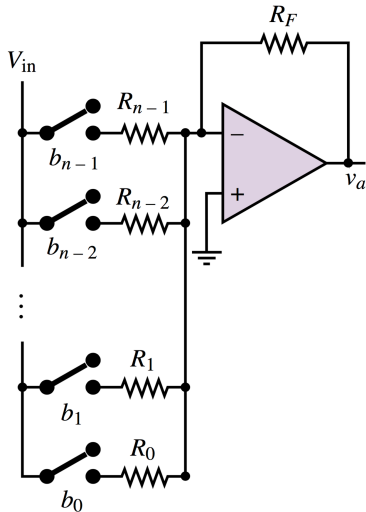

Similar to [summing amplifier](#):

$$v_a = - \sum_i \left(\frac{R_F}{R_i} \cdot b_i \cdot v_{in} \right)$$



DAC Type 1: Weighted Adder DAC

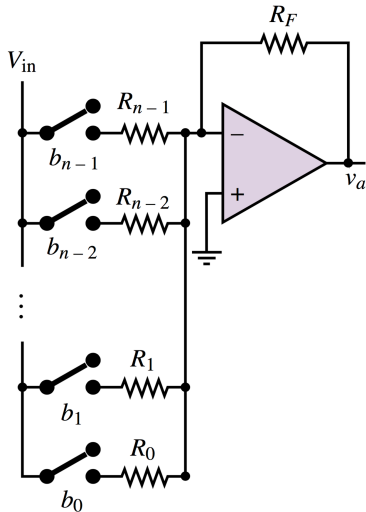

Similar to [summing amplifier](#):

$$v_a = - \sum_i \left(\frac{R_F}{R_i} \cdot b_i \cdot v_{in} \right)$$

If we select $R_i = \frac{R_0}{2^i}$:

$$v_a = - \frac{R_F}{R_0} (2^{n-1} b_{n-1} + \dots + 2^1 b_1 + 2^0 b_0) \cdot v_{in}$$

Note here V_{-ref} is 0 (ground)



DAC Type 1: Weighted Adder DAC

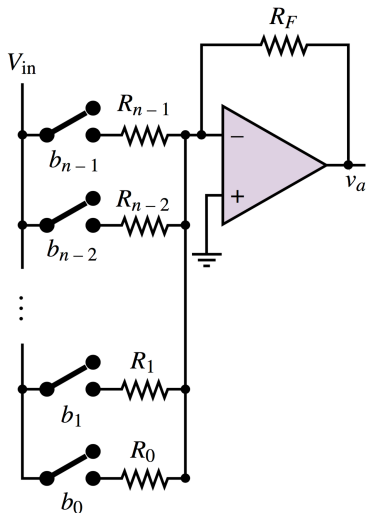

Limitations:

- Impossible to fabricate a **wide range** of resistor values in the same IC chip

Similar to **summing amplifier**:

$$v_a = - \sum_i \left(\frac{R_F}{R_i} \cdot b_i \cdot v_{in} \right)$$

If we select $R_i = \frac{R_0}{2^i}$:

$$v_a = - \frac{R_F}{R_0} (2^{n-1} b_{n-1} + \dots + 2^1 b_1 + 2^0 b_0) \cdot v_{in}$$

Note here V_{-ref} is 0 (ground)



Question: 4-bit DAC

For given $(b_3b_2b_1b_0) = \{(1111), (0000), (1010)\}$, calculate v_a .

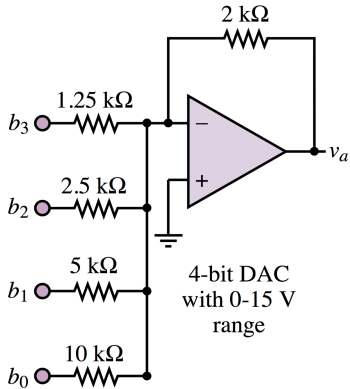

Practical Resistor Network DAC and Audio Amplifier

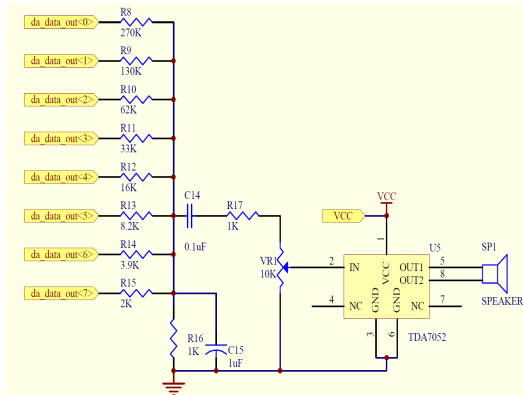

Data Bit	Ideal R	Real R
0 (LSB)	256K	270K
1	128K	130K
2	64K	62K
3	32K	33K
4	16K	16K
5	8K	8.2K
6	4K	3.9K
7 (MSB)	2K	2K

► Not perfect, but okay.



DAC Type 2: R-2R DAC

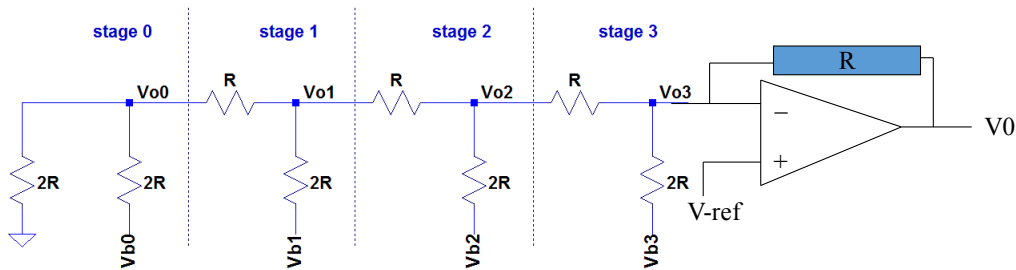

Motivations:

- ▶ Use only **two** values of resistors which make for easy and accurate fabrication and integration
- ▶ At each node, current is split into 2 equal parts
- ▶ The most popular DAC



DAC Type 2: R-2R DAC

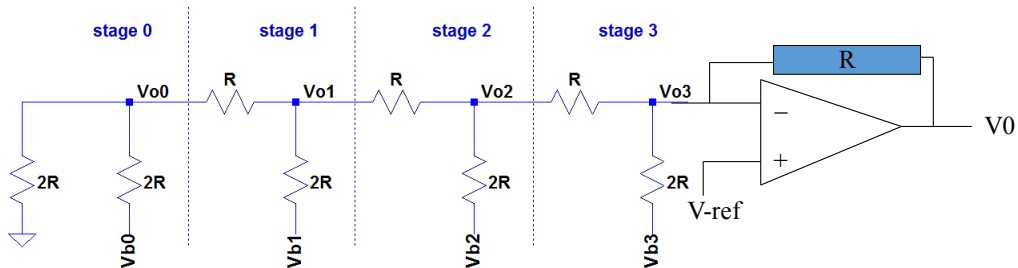

Reference:

<http://www.tek.com/blog/tutorial-digital-analog-conversion—r-2r-dac>

DAC Type 2: R-2R DAC

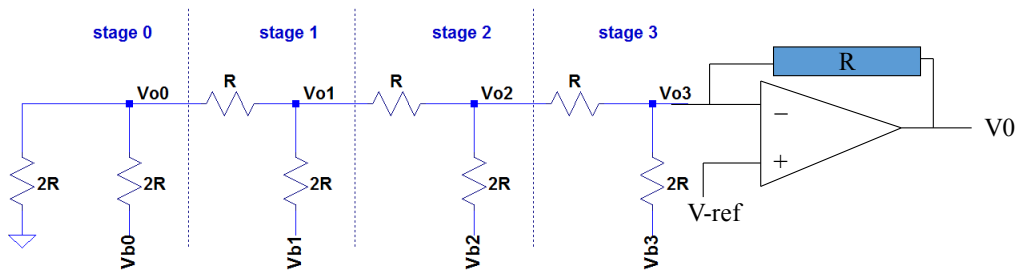

Given I as input value (n bit):

$$V_{o3} = \frac{V_{b0}}{16} + \frac{V_{b1}}{8} + \frac{V_{b2}}{4} + \frac{V_{b3}}{2}$$



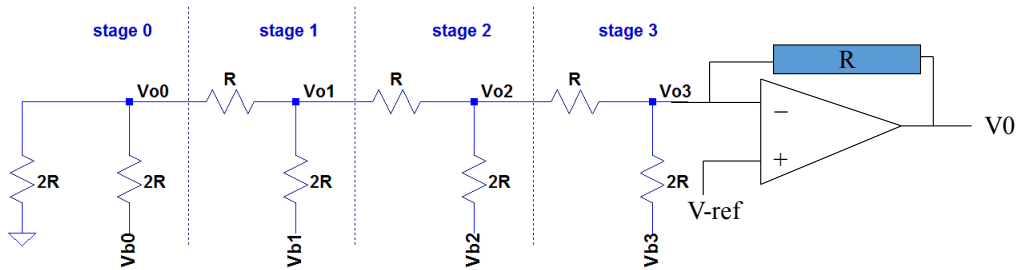

Question: R-2R DAC

For given $(b_3b_2b_1b_0) = \{(1111), (0000), (1010)\}$, calculate v_{o3} .



Overview

Preliminaries

Comparator

Digital to Analog Conversion (DAC)

Analog to Digital Conversion (ADC)



Analog-to-Digital Converter (ADC)

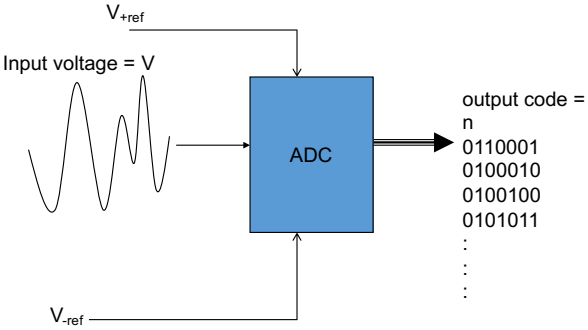

Quantization

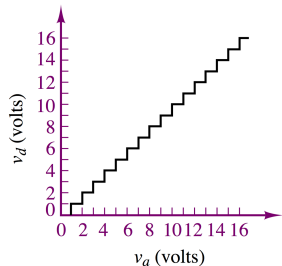

Quantized voltage	Binary representation				
	v_d	b_3	b_2	b_1	b_0
0	0	0	0	0	0
1	0	0	0	1	1
2	0	0	1	0	0
3	0	0	1	1	1
4	0	1	0	0	0
⋮					
14	1	1	1	1	0
15	1	1	1	1	1

- ▶ Convert an analog level to digital output
- ▶ Employ $2^n - 1$ intervals (n : bit#)
- ▶ v_a : analog voltage
- ▶ v_d : output digital voltage



ADC Type 1: Integrating ADC

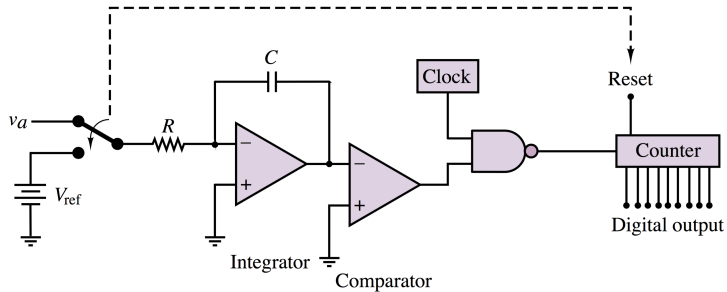

- ▶ Accumulate the input current on a capacitor for a fixed time
- ▶ Then measure time (T) to discharge the capacitor
- ▶ When cap is discharged to 0 V, comparator will stop the counter



ADC Type 1: Integrating ADC

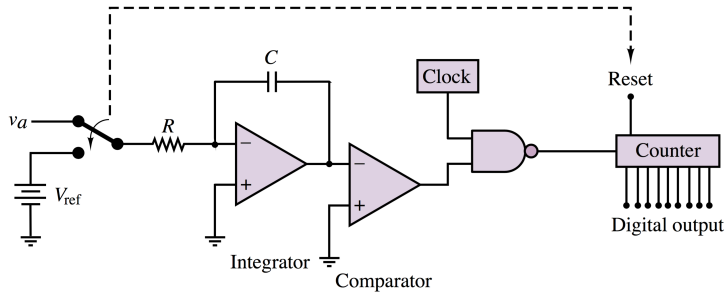

- ▶ Accumulate the input current on a capacitor for a fixed time
- ▶ Then measure time (T) to discharge the capacitor
- ▶ When cap is discharged to 0 V, comparator will stop the counter

Limitation: Slow



ADC Type 2: Tracking ADC

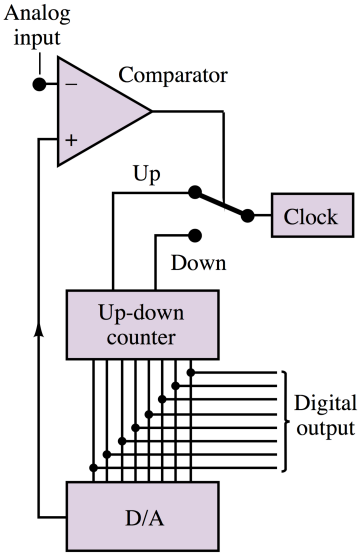

- ▶ ADC repeatedly compares its input with DAC outputs
- ▶ Up/down count depends on input/DAC output comparison



ADC Type 2: Tracking ADC

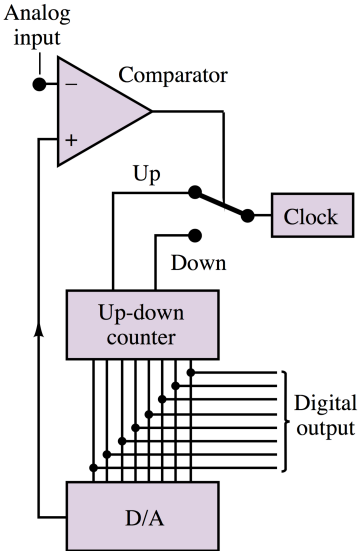

- ▶ ADC repeatedly compares its input with DAC outputs
- ▶ Up/down count depends on input/DAC output comparison

Limination: Slow



ADC Type 3: Successive Approximation

- ▶ Replace “Up-down counter” by “control logic”
- ▶ Binary search to determine the output bits
- ▶ still slow although faster than types 1 & 2

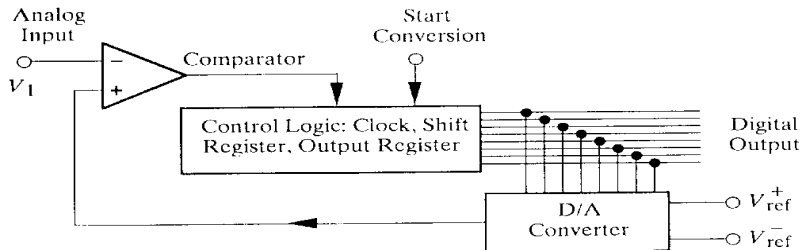

Flow chart of Successive-approximation ADC

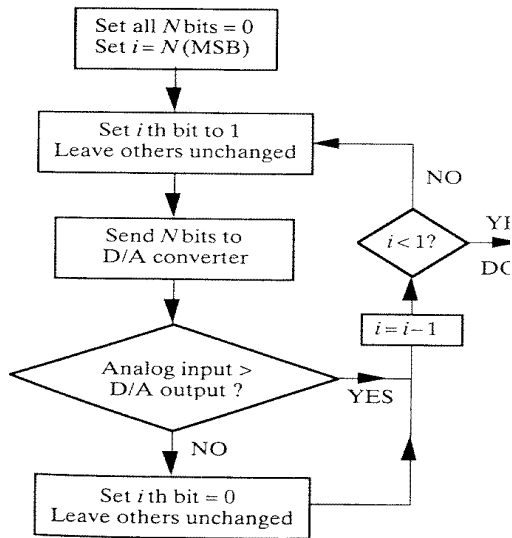

ADC Type 4: Flash ADC

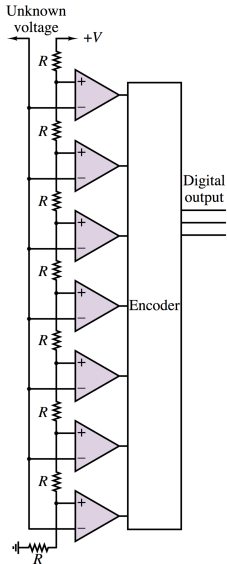

- ▶ Divide the voltage range into $2^n - 1$ levels
- ▶ Use $2^n - 1$ comparators to determine what the voltage level is
- ▶ Fully parallel

Pros:



ADC Type 4: Flash ADC

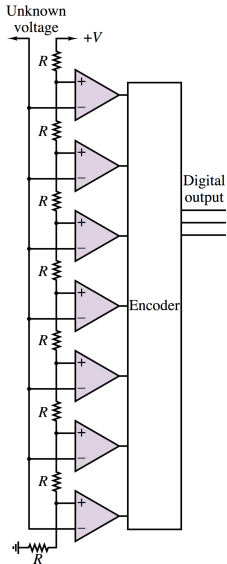

- ▶ Divide the voltage range into $2^n - 1$ levels
- ▶ Use $2^n - 1$ comparators to determine what the voltage level is
- ▶ Fully parallel

Pros:

- ▶ Very fast for high quality audio and video
- ▶ Sample and hold circuit **NOT** required

Cons:



ADC Type 4: Flash ADC

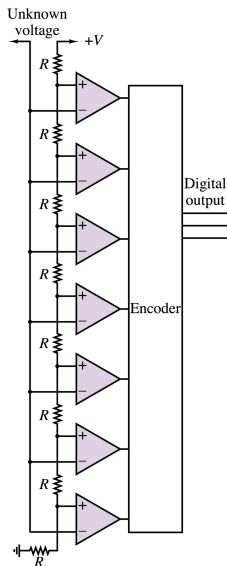

- ▶ Divide the voltage range into $2^n - 1$ levels
- ▶ Use $2^n - 1$ comparators to determine what the voltage level is
- ▶ Fully parallel

Pros:

- ▶ Very fast for high quality audio and video
- ▶ **Sample and hold** circuit **NOT** required

Cons:

- ▶ Very expensive for wide bits conversion

