



香港中文大學
The Chinese University of Hong Kong



JS4460

BEng (Hons) in Biomedical Engineering

Offered by Department of Biomedical Engineering
The Chinese University of Hong Kong

EXPLORE
INNOVATE
CARE

EXPLORE

INNOVATE



CARE

Department of Biomedical Engineering,
The Chinese University of Hong Kong, Shatin,
N.T., Hong Kong

(852) 3943 1935

<http://www.bme.cuhk.edu.hk>

bmeinfo@cuhk.edu.hk

CuhkBiomedicalEngineering

bmedept

香港中文大学生物医学工程系 _BME



What is Biomedical Engineering?

Biomedical Engineering (BME) is an **interdisciplinary programme** offered by the *Faculty of Engineering* in close collaboration with the *Faculty of Medicine*. It involves the use of **engineering principles** to solve **biological** and **medical** problems for the welfare of mankind.

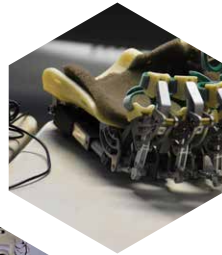
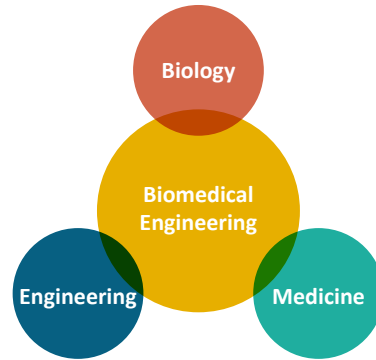

Programme Highlights

- Supported by the CUHK Faculty of Engineering and Faculty of Medicine in teaching and research.
- Accredited by the Hong Kong Institution of Engineers (HKIE), ample opportunities for industrial and academic placements.
- Around 26% of our graduates pursue further studies in various engineering and medical disciplines (some all the way to PhD).
- With the Prince of Wales Hospital as our teaching hospital, students will have opportunities to learn on-site how technology may enhance clinical services and patient benefits.
- CUHK private hospital has been launched in 2021.
- Students with outstanding academic records are eligible for potential enrollment in the CUHK MBChB program in an accelerated track.

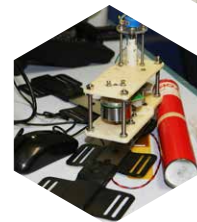

Admission Criteria

1. JUPAS Admission (JS4460)

We look for students who like science subjects, love to EXPLORE, INNOVATE and CARE, passionate for learning in breadth as well as in depth, ready to acquire new knowledge across disciplines, and eager to apply their learning to solve real-life problems in the medical and healthcare industries.

Students are expected to have completed at least two elective subjects plus the four core subjects. Priority score are computed based on the Best 5 HKDSE subject results with subject weighting as below:

4 Core Subjects	Minimum Level	Subject Weighting
English Language	3	1.5
Chinese Language	3	1
Mathematics (Compulsory Part)*	3	1.5
Liberal Studies	2	1
2 Elective Subjects	Minimum Level	Subject Weighting
Biology / Chemistry / Physics / Combined Science / Mathematics Extended Module (M1 / M2)*	3	1.5
Other elective Subject	3	1

*Subject weighting of "1.5" is given to the best Mathematics subject (either the core Mathematics or the M1/M2 Extended Module)

2. Non-JUPAS (local) / International Student Admission

Local and non-local students with other qualifications can also apply through the non-JUPAS admission scheme. These qualifications include GCE, IB, SAT / AP and other overseas qualifications for university admission. Preferences are given to applicants with good grades in at least two of the following subjects - Physics, Chemistry, Biology, or Mathematics. More detailed information are available at <http://admission.cuhk.edu.hk/non-jupas-yr-1/requirements.html> (Non-JUPAS local) and <http://admission.cuhk.edu.hk/international/requirements.html> (Non-JUPAS International).

A non-JUPAS applicant may apply for "Admission with Advanced Standing" if he / she meets specific requirements (including GCE-AL, IB-HL, etc.). For students admitted with Advanced Standing, the number of units for graduation may be reduced by up to 24. Applicants should indicate in the application form whether they would like to be considered for "Admission with Advanced Standing".

3. Senior-Year Admission for Sub-degree Holders

Students with a Higher Diploma / Associate Degree from local institutions can apply for the senior year admission in Biomedical Engineering. For details, please refer to the website of the Office of Admissions and Financial Aid

<http://admission.cuhk.edu.hk/non-jupas-senior/requirements.html>

4. Mainland Gao Kao Admission

Mainland Students, who are current Gao Kao candidates, should apply through the National Colleges and Universities Enrollment System. More detailed information are available at

<http://admission.cuhk.edu.hk/sc/mainland/requirements.html>

Scholarships

Ample scholarships are available through multiple sources - the Office of Admission and Financial Aids, Colleges, Faculty of Engineering, as well as Department of Biomedical Engineering to encourage students to participate in international competitions and conferences.

In 2021, over 25% of our newly admitted students have received Admission Scholarship (in one-off or renewable offer). The highest admission scholarship received is up to HK\$145,000 per academic year.



BME Curriculum

Total Units Requirements: at least 123 units			
	Major Programme Requirements (75 units)	University Core Requirements (39 units)	Free Electives* * Units for free electives can be used to fulfil the minor requirement
Year 4 or 5	Graduation Project Electives for BME Streams	English	
Year 4	One-year Work-study Programme (optional)	Chinese	
Year 3	Advanced BME Major Courses Biomaterials and Tissue Engineering, Medical Instrumentation and Design, Global Medical Device Regulations	General Education Physical Education	
Year 2	Fundamental BME Major Courses Anatomy and Physiology, Biomechanics, Cell and Molecular Biology, Circuits and Signals, Engineering Mathematics	IT# # The 1-unit course will be exempted for Engineering graduates	
Year 1	Engineering Foundation Biology / Chemistry / Physics, Engineering Mathematics, Programming		

Streams

Medical Instrumentation & Biosensors

- TeleMedicine & Mobile Healthcare
- Cardiovascular Engineering
- Biofluids
- Bionanotechnology
- Neuroengineering
- Microelectronic Devices and Circuits
- Medical Robotics
- Introduction to Digital and Microprocessor Systems
- Body Sensor Networks
- Advanced Imaging and Spectroscopy Techniques in Biomedicine
- BioMEMS

Recommended to minor in Electronic Engineering, Mechanical & Automation Engineering, OR Physics

Biomedical Imaging, Informatics & Modeling

- Bioinformatics
 - Big Data in HealthCare
 - Biomedical Modelling
 - Data Analytics for Personalized Genomics and Precision Medicine
 - Database and Security for Biomedical Engineering
 - Biomedical Imaging Applications
 - Advanced Imaging and Spectroscopy Techniques in Biomedicine
- Recommended to minor in Computer Science, OR Electronic Engineering*

Molecular, Cell & Tissue Engineering

- Cell Biology
 - BioMEMS
 - Genetic Engineering
 - Biofluids
 - Bionanotechnology
 - Musculoskeletal Tissue Engineering
 - Biomolecular Engineering
- Recommended to minor in Biology, OR Biochemistry*

BME + Business Administration Double-Degree Programme

- 1st degree: Bachelor of Engineering (Biomedical Engineering)
 - 2nd degree: Bachelor of Business Administration (Integrated BBA Programme)
 - Collaborated with the Faculty of Business Administration
- For further information, please refer to the Faculty website at <http://www.erg.cuhk.edu.hk/erg/ergbba>*

BME Minor Programme

- Students can take up to two minors programmes
- 18-30 units for each minor programme

Biomaterials and Regenerative Medicine

Biomaterials scaffolds, stem cell technology, microenvironmental cues in stem cell differentiation, biophysical stimulation and mechanobiology.



Biomolecular Engineering and Nanomedicine

Lab-on-a-chip biosensors, point-of-care devices, microfluidic manipulation and detection of biomolecules, bionanotechnology and delivery of diagnostic and therapeutic molecules.

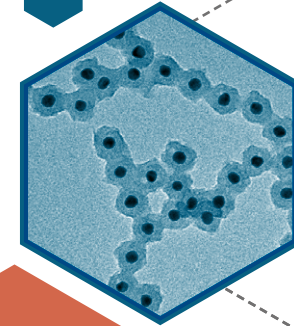

Medical Instrumentation and Biosensors

Wearable sensors and mobile health, home healthcare technology, surgical robotics, wireless capsule endoscopy, wearable robotics for rehabilitation.



Medical Imaging and Informatics

Computer-aided diagnosis, functional magnetic resonance imaging, terahertz imaging and spectroscopy, biomedical optics, bioinformatics, health informatics, telemedicine.

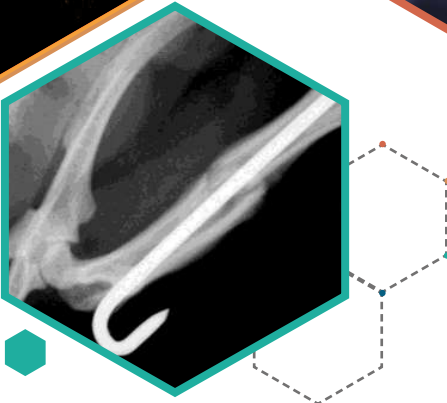

Practical Training

Students are required to participate in a four-week professional and practical summer training on CUHK main campus and at Prince of Wales Hospital (PWH). The in-house training involves electronic circuit design, simulation, fabrication, interfacing with software, data acquisition, and wireless communication, while the hospital training, students can experience the daily operation information flow and logistics in the running of a hospital. They will also learn about the fundamentals and the clinical use of medical instruments. The training provides a valuable chance for students to relate theory and engineering knowledge to practice in a real-world setting.

Students' Sharing

Aiana BAEKOVA (Class of 2022)

Choosing a major is one of the most important decisions people make in their lives. It has to be something they will not regret spending 4 years on. I believe I made the right choice by joining BME!

In BME, not only we acquire knowledge from various subjects but also we learn how to apply those skills. During my first year, BME conducted summer training for all undergraduate students. The training helped me to see real-life applications of the concepts learned in class, and gave me an insight view on the working environment of biomedical engineers. All the hospital visits, medical instrumentation company visit and the laboratories motivate aspiring engineers, like me, to keep working and make a contribution later in lives.

As an international student, I had some difficulty finding local friends but BME summer training changed that. BME Summer Training is what brought both local and non-local students together by dividing us into groups. Despite the short time we spent together as a group, we still were able to make vivid memories together! I am very grateful to the department for this opportunity!

Explore, innovate and care together with BME!



Nico CHEN (Class of 2017)

The training was eye-opening and exposed us to multitudinous hospital equipment and facilities, granting us a real-time perception of the state-of-the-art technologies adopted by hospital personnel. We were invited to observe the machinery operation on patients with their consent, polishing our viewpoint on our role as biomedical engineers of the next generation.

Graduation Project

Medical Instrumentation & Biosensors

- Developing a Wireless Implantable Intraocular Continuous Glucose Monitor Using Near Field Communication

Supervised by Department of Ophthalmology & Visual Sciences, Year 2018-19

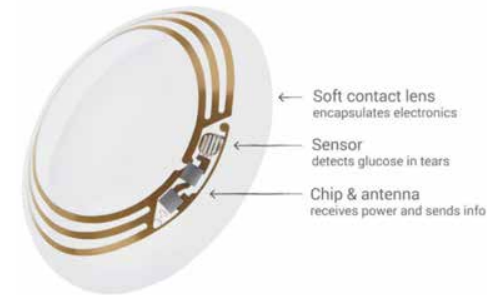

- Biomimetic Soft Crawling Robot for GI Tract Inspection

Supervised by Department of Surgery, Year 2017-18

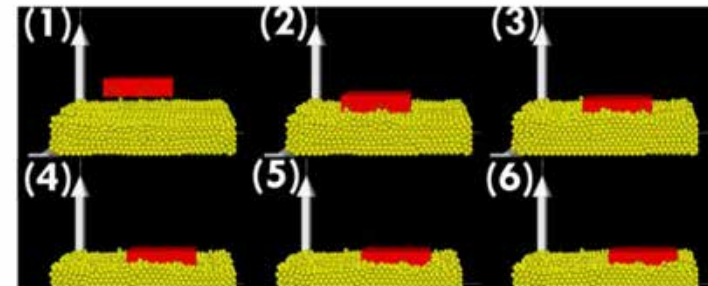

Discrete particle simulation on the preliminary prototype design

Biomedical Imaging, Informatics & Modeling

- Automated Lenke Classification of Adolescent Idiopathic Scoliosis Using Deep Learning

Supervised by Department of Imaging and Interventional Radiology, Year 2018-19



● ERP Study on Tone Perception in Hearing Impaired Conditions

Supervised by Department of Electronic Engineering, Year 2017-18

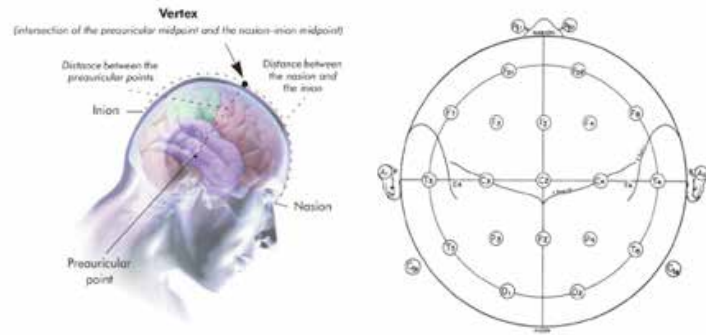

Molecular, Cell & Tissue Engineering

● Roles of Osteocyte in Osteoporotic Fracture Healing

Supervised by Department of Orthopaedics & Traumatology, Year 2018-19

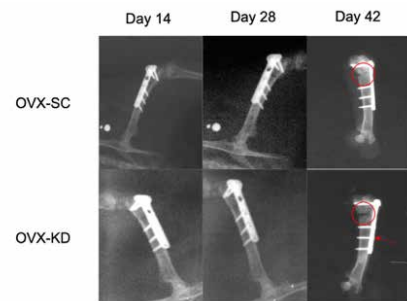

Serial radiographs of OVX-KD and OVX-SC at day 14, 28 and 42

● Design and Development of a 3D Culture Platform by Droplet Microfluidics

Supervised by Department of Biomedical Engineering, Year 2017-18

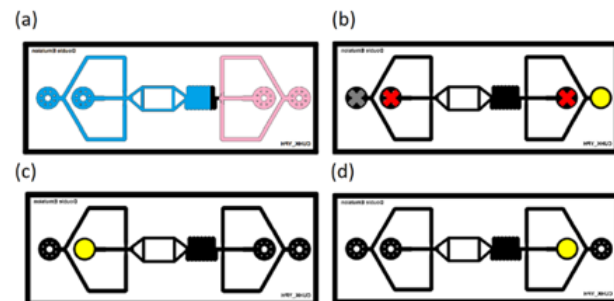

● Experiential Learning

Based on interests, students are encouraged and supported to participate in various experiential learning activities, such as academic exchanges, community services, early research exposures, international design competitions, study filed trips, summer internships, work-study, etc. Examples are provided below.

Design Competitions

- iGEM, International Genetically Engineered Machine Competition at Giant Jamboree in Boston, USA
- Engineering Medical Innovation Global Competition
- Hong Kong University Student Innovation and Entrepreneurship Competition
- ASM Technology Competition

Local Summer Industrial Internships

- Academy of Science Shenzhen Institute of Advanced Technology
- Philips Electronics Hong Kong Ltd., etc.
- Johnson & Johnson Medical Devices Hong Kong
- Hospitals such as the Hong Kong Adventist Hospital and Prince of Wales Hospital
- Hong Kong Government Electrical and Mechanical Services Department
- Hong Kong Productivity Council

Overseas Summer Research Internships

- University of California at Irvine
- Columbia University
- Imperial College
- Korea Institute of Science & Technology
- Northwestern University
- University of Pittsburgh
- National University of Singapore
- University of Toronto
- Nanyang Technological University
- The University of California
- University of California at San Diego
- University of Illinois at Urbana-Champaign



Students' Sharing

Overseas Summer Research Internship

WANG Haonan Nancy (Class of 2020)

participated in Summer Overseas Research Internship Programme 2018 at School of Mechanical and Aerospace Engineering, Nanyang Technological University, Singapore

In this summer, I have participated in BME Overseas Summer Research Internship programme in Nanyang Technological University of Singapore. During the internship, I did some research in the field of Digital Microfluidic Point-of-Care Platform. This experience has benefited me a lot. I have gained a valuable academic experience and developed my research skills and interpersonal strengths. I believe those will be helpful to me in my further study.

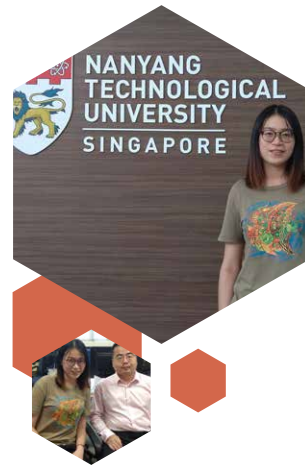

International Genetically Engineered Machine Competition (iGEM)

CHAN Nga Yan Yvonne (Class of 2019)

received gold medal as a member of the CUHK school team at the iGEM Competition 2018 Giant Jamboree held in Boston, USA

As a member of the BME family, I had plenty of chances to participate in different activities. iGEM is one of them. iGEM is a competition that aims at exploring a new way to solve real-life problems with the help of synthetic biology. It provides me with hand-on experience and I also got many inspiring ideas from other teams!



Overseas Exchange

University provides overseas exchange opportunities to students to immerse in multi-cultural settings and to enrich their study life and personal experience. Many undergraduate students in Biomedical Engineering participate in overseas exchange programmes around the world. Recent examples include:

- Ewha Womans University, Korea
- Karlsruhe Institute of Technology, Germany
- KTH Royal Institute of Technology, Sweden
- Nanyang Technological University, Singapore
- National University of Singapore, Singapore
- Pompeu Fabra University, Spain
- San Diego State University, USA
- State University of New York at Stony Brook, USA
- University College London, UK
- University of Illinois at Urbana-Champaign, USA
- University of Ottawa, Canada
- University of Tennessee, USA
- University of Western Australia, Australia

Work-Study Programme

Students can choose to participate in "Work-Study Programme" upon completion of the third year of their major study. The Programme provides students an opportunity to apply engineering principles and methods from their studies to an authentic working environment. Students will continue their final year of study on campus afterwards. Partners include Hospital Authority, private hospitals, companies from the biomedical engineering industries. Recent examples include:

- Asia Satellite Telecommunications Company Limited
- ASM Technology Hong Kong Limited
- Automatic Manufacturing Limited
- Electrical and Mechanical Services Department, HKSAR Government
- Hong Kong Productivity Council
- The Hong Kong and Shanghai Banking Corporation Limited (HSBC)
- ITE Smartcard Solutions Limited
- Medisen Limited
- Ove Arup & Partners Hong Kong Limited
- Paul C. Lauterbur Research Centre

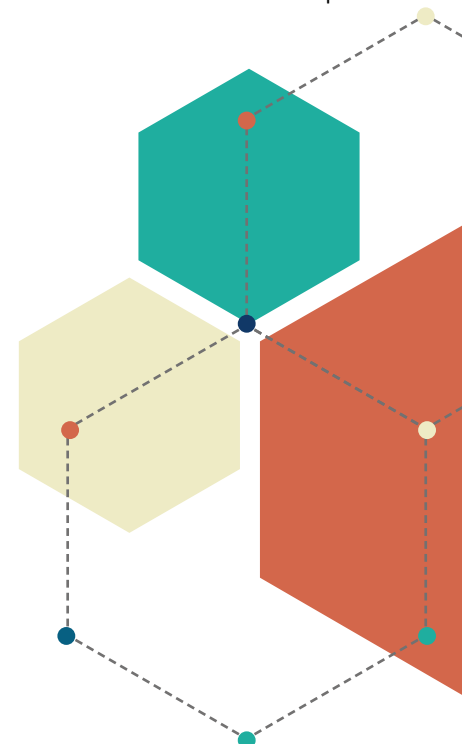

Career Opportunities

Employment of biomedical engineers is expected to grow much faster than the average for all occupations. The aging population and the focus on health issues will increase the demand for better medical devices and equipment. The development of biomedical engineering is therefore a worldwide trend. Our graduates are pursuing the following career paths.

- Manufacturing Industries
- Clinical Engineers in Hospitals
- Entrepreneurs in Biotech Companies
- Regulatory Affairs
- Distribution & Sale
- Testing Laboratories
- Research Scientists & Engineers
- Further Studies (MSc, PhD, MD, MBA, PCLL)

BME Graduates Employment Survey (13,14,15,16,17,18,19,20)

Others

- Hong Kong Aircraft Engineering Computer Limited
- Hospital Authority
- Hong Kong Productivity Council
- HSBC
- New World Construction

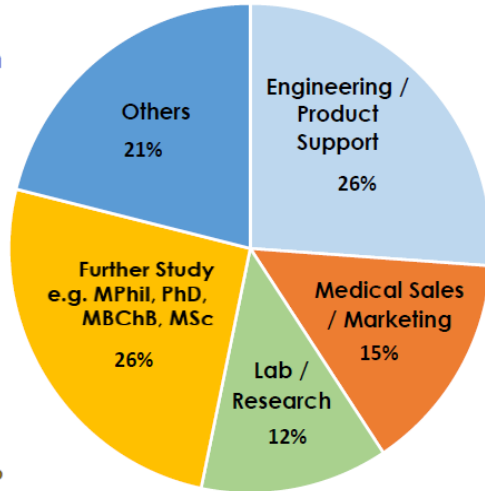

Engineering / Product Support

- Electrical and Mechanical Services Department
- Celki Vitalaire
- ASM
- AB Sciex
- ArjoHuntleigh
- Healthlink Holdings Limited
- Eppendorf China Limited
- Data Innovations Asia
- Medisource Supply (Asia)
- Sanwa Biotech Limited
- Hong Kong Adventist Hospital
- CUHK Medical Centre

Medical Sales / Marketing

- Johnson & Johnson
- Kerry Medical Limited
- Boston Scientific
- Philips
- Siemens
- Ultronics Enterprise Limited

Lab / Research

- CUHK
- ASTRI

Further Study

- The University of Tokyo
- National University of Singapore
- University of California San Diego
- Imperial College London
- Royal Holloway, University of London
- CU Medicine, Hong Kong
- CU Nursing, Hong Kong

BME Alumni Sharing

NG Wing Yin Ben

2019 BEng (Biomedical Engineering) graduate
Research Assistant, The Chow Yuk Ho Technology Centre
for Innovative Medicine, CUHK

When I had to declare my major program (as a Year 1 board-based Engineering student), I quickly chose BME as my first priority. And it turns out that this choice is definitely correct. As an interdisciplinary program, BME provides knowledge not only for engineering, but also knowledge of how to relate engineering techniques to real medical problems. We can study multiple fields of BME, such as biomaterial, medical robotics, and neuroengineering, etc. All these have broadened our horizon on cutting-edge biomedical techniques.



Now, I am a research assistant of the Chow Yuk Ho Technology Centre for Innovative Medicine, CUHK. I mainly focus on soft robot control and development of endoscope. The undergraduate study in BME has equipped me with a solid foundation in engineering and medical science, and chances of exploring different interesting topics. These help me to be more well-prepared for my current research, and even my possible future study.



CHUNG Pui Wo Tommy
2019 BEng (Biomedical Engineering) graduate
Assistant Service Engineer, Celki Vitlaire

Currently, I work as an assistant service engineer (Sleep Team) in Celki Vitlaire. My job is to process the polysomnography test for the patients, analyze (score) the sleep report manually and send it to the doctors. The PSG test is for diagnosing sleep disorders, especially sleep apnea. A precise PSG analysis can help patients figure out their symptoms, helping doctors in curing patients.

In BME courses, we have learned different human psychological signals, especially the EEG. There are alpha waves found in O1, O2 at sleep stage N1....etc. In this industry, I can apply what I learned in BME as well as engineering senses to troubleshoot problems dealing with different types of medical devices.

If you are really interested in handling EEG, EOG and ECG, you could consider to be a Registered Polysomnographic Technologist (RPSGT), the specialist in this industry, apply what you have learned in BME.

SHUM Ka Yu Sam
2017 BEng (Biomedical Engineering) graduate
Assistant Engineer, Electrical and Mechanical Services
Department, HKSAR Government

Population expansion and the prevalence of aging have accelerated the growth of healthcare services. To support the delivery of medical and clinical services, BME engineers play a significant role in the discipline of medical devices by bringing constant improvements in safety, efficacy, and quality. CUHK BME has equipped graduates with a solid foundation in engineering and medical sciences. Examples of which include electronic design, hands-on practice in circuitry, in-depth understanding of physio- and medical phenomena. Topics related to regulatory affairs have ensured that students are well aware of the importance of market requirements concerning quality and risk management. The exposure to clinical environment and making contact with industry professionals also help students explore their potential and career prospects in various fields of BME.



AU Chun Ki Franklin
2018 BEng (Biomedical Engineering) graduate
Student, MPhil in Imaging and Interventional Radiology, CUHK

I am honored to be part of the family of CUHK BME. As an inter-disciplinary subject, BME offers us an excellent learning platform and abounding scientific research opportunities. Not only do we benefit from receiving forefront knowledge about the world of engineering and medicine, our horizon on cutting-edge biomedical technology also gets expanded.

My BME undergraduate experience has opened the doors for advancing my studies in medicine. As a Biomedical Engineer, I found myself well-prepared in a variety of medicine-related specialties including Interventional Radiology and Imaging - a topic which I have chosen for my further study.

Passionate professors in CUHK BME have inspired and nurtured my creativity for medical devices and related technologies. With their open assistance, I recently invented my first medical device for stroke rehabilitation. The device also helped me win the Golden Technopreneur Award 2017 organised by Hong Kong Science & Technology Park Corporation (HKSTPC).

The revolution is now upon us. "Explore, Innovate and Care" - the Motto of CUHK Biomedical Engineering - is the promise for this fast-changing industry. I feel grateful that Biomedical Engineering of CUHK has prepared me to become a highly-qualified professional in this booming sector. I look forward to contributing to this challenging industry in the future.

SIN Ka Man Carmen
2017 BEng (Biomedical Engineering) graduate
Assistant Engineer, Electrical and Mechanical
Services Department, HKSAR Government

In this day and age, the awareness of the safety, efficacy, and quality of medical devices in Hong Kong is always increasing. This in turn has given rise to a need for new legislation concerning medical devices, and therefore more opportunities for the likes of me and others studying BME. The BME programme educates students on a variety of theoretical concepts concerning engineering, biology and medical sciences. This, coupled with the practical skills gained in course such as Global Regulatory Affairs and exposure to a clinical environment, has led me to a career as a biomedical engineer, acting as a middle man between both medical and engineering experts.

