

Fiber optic angular displacement sensor

Chi Wu

Department of Chemistry, The Chinese University of Hong Kong, Shatin, N. T., Hong Kong

(Received 3 June 1994; accepted for publication 29 January 1995)

A reflective type fiber optic angular displacement sensor has recently been developed, which consists of a light source, an optical isolator, a four-port single-mode fiber bidirectional coupler, and a light intensity detection system (two silicon photodetectors and an analog divider). By using a normal He-Ne laser with $\pm 2\%$ stability in light intensity, we have achieved an angle resolution of 10^{-6} rad. In this paper, its design principle, instrumentation, calibration results, and sensitivity test have been reported. In addition, possible applications of this sensor, such as in an atomic force microscope, and some feasible improvements of this sensor are discussed. © 1995 American Institute of Physics.

I. INTRODUCTION

Due to the advancement of the fiber optic technique, various types of fiber optic sensors have recently been developed to measure a very small displacement or vibration (in the scale of angstrom or even subangstrom) of a detected surface. Most of the reported sensors have used interferometric techniques.¹ In an interferometric type fiber optic sensor, the interference between the light reflected from the fiber-air interface and the light scattered back from the reflecting surface is monitored with a low light sensitive optical detector, such as a photomultiplier tube. This type of fiber optic displacement sensor has found many applications in practice. For example, it has been used in an atomic force microscope (AFM) by Rugar *et al.*² However, strictly speaking, the displacement of the microcantilever in AFM is an angular displacement because one end of the microcantilever is fixed and the other end with a microfabricated tip is deflected by the magnetic, electrostatic, and the interatomic interaction between the tip and the sample.³

Considering the increasing demands for using optical methods to monitor a very small angular displacement, such as in AFMs, we present here a simple reflective type fiber optic angular displacement sensor, wherein a few optical components and a simple light-intensity detecting system are used.

II. INSTRUMENTATION

Figure 1 shows a schematic presentation of our fiber optic angular displacement sensor, wherein a normal 5 mW He-Ne laser (Aerotech OEM5P), a single-mode fiber bidirectional coupler (Newport F-506B), and two silicon photodetectors (D1 and D2) are used. The laser light after passing through an optical isolator (I) (Isowave I-633-2) is fed into the fiber end (P1) by using a high-precision single-mode fiber coupler (L1) (Newport F-1015). The light fed into the fiber end (P1) is split into two parts with equal intensity by the bidirectional coupler. The light emitted from the fiber end (P4) is used as a reference for monitoring the laser intensity drift and fluctuation. The light emitted from the fiber end (P2) is collimated by using a microscope objective lens (L2) ($f=8.3$ mm). The collimated light beam is reflected back by a mirror (M) and then the backreflected light is recoupled

into P2 by L2. The light entering P2 is also split into two equal parts by the bidirectional coupler. The backreflected light emitted from P1 is stopped by I so that the retroreflections of the light into the laser cavity can be greatly reduced. The backreflected light emitted from P3 is used to monitor the intensity of the backreflected light. The intensities of the lights emitted from P3 and P4 are first converted into the voltage signals (V1 and V2) by D1 and D2, respectively, and then V1 is divided by V2 by using an analogue divider which has a bandwidth of ~ 10 kHz. The output voltage signal from the divider, i.e., $V=V1/V2$, can be recorded by an IBM/PC-AT computer. Since the intensity of the backreflected light is strong enough, it is not necessary to use a voltage amplifier in our light-intensity detecting system.

Based on the signal-to-noise-ratio (SNR) analysis,⁴ the SNR of the measured intensity should be ~ 84 dB, if the received optical power at the detector is $10 \mu\text{W}$, the detection bandwidth is 10 kHz and the detector load resistance is 10 k Ω . Therefore, the theoretical sensitivity in intensity should be better than 1 part in 10^8 . In standard practice, the order of 10 dB margin is required, which means that the resolution in intensity, in principle, could be 1 part in 10^7 .

III. BASIC PRINCIPLES

Figure 2 schematically shows the principle of our fiber optic angular displacement sensor. When the mirror is placed perpendicularly to the collimated light, the backreflected light will be completely recoupled into the fiber end. If the mirror rotates an angle of θ from the initial perpendicular position, the backreflected light will be tilted by an angle of 2θ and the center of the backreflected light will shift from the point O to O', i.e., a distance of

$$x=2\theta f, \quad (1)$$

where f ($=8.3$ mm) is the focal length of the lens and $\theta=d/L$ since θ is a very small angular displacement, i.e., $d \ll L$. In this case, only part of the backreflected light will be recoupled into the fiber end by the lens so that the intensity of the light emitted from P3 (i.e., V1 or further V, see Fig. 1) will decrease. Therefore, by monitoring the change in the output voltage (V), we are able to measure the angular displacement of the mirror.

Fiber Optic Angular Displacement Sensor (FOADS)

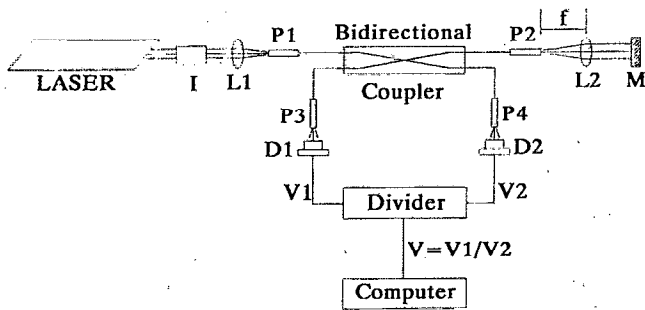

FIG. 1. Schematic presentation of the reflective type fiber optic angular displacement sensor, which consists of a laser, an optical isolator (I), two fiber couplers (L1 and L2), a four-port single-mode fiber bidirectional coupler, and a light-intensity detection system (two silicon photodetectors D1 and D2, an analogue divider, and an IBM/PC AT computer). *M* is a reflecting surface.

Figure 3 schematically shows how the backreflected light is recoupled with the single-mode fiber end which has a radius of $R = 2 \mu\text{m}$. It is known that this so-called single-mode fiber is not a true single-mode optical system for 633 nm light, but supports a small number of modes so that the light intensity emitted from the fiber end is not uniform around the light core. However, the variation is small. Therefore, in the following, we will assume that the backreflected light intensity is uniform in order to simplify our discussion. In Fig. 3, the amount of the backreflected light recoupled into the fiber end will be proportional to the overlap area between the backreflected light beam and the fiber end, i.e., four times of the area ABC . The area ABC is the area difference between the area $O'BC$ and the area $O'AC$. Therefore, we have

$$I \propto 4 \left(\frac{\Phi}{2\pi} \pi R^2 - \frac{1}{2} \frac{x}{2} R \sin(\Phi) \right) = \pi R^2 \left(\frac{2\Phi}{\pi} - \frac{x}{R} \frac{\sin(\Phi)}{\pi} \right), \quad (2)$$

where $x < 2R$,

$$\Phi = \cos^{-1} \left(\frac{x/2}{R} \right) = \frac{\pi}{2} - \sin^{-1} \left(\frac{x/2}{R} \right) = \frac{\pi}{2} - \left[\left(\frac{x/2}{R} \right) + \frac{1}{6} \left(\frac{x/2}{R} \right)^3 + \frac{3}{40} \left(\frac{x/2}{R} \right)^5 + \dots \right] \quad (3)$$

and

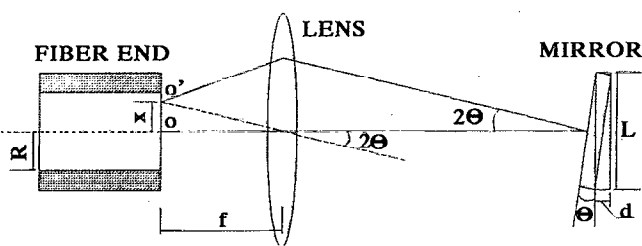

FIG. 2. Schematic presentation of the basic principle of the reflective type fiber optic angular displacement sensor (see the text for details).

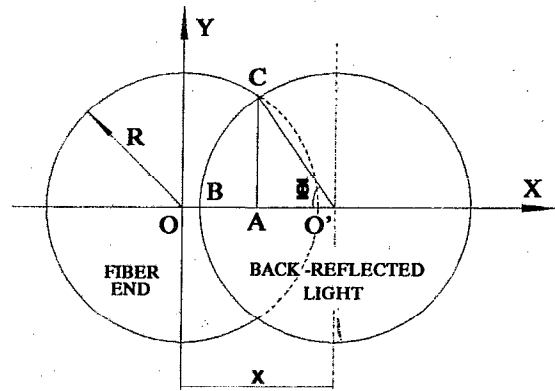

FIG. 3. Schematic presentation of how the backreflected light is recoupled with the fiber end, where we have assumed that the light beam is perfectly collimated, i.e., the backreflected light beam and the fiber core have the same radius (R).

$$\sin(\Phi) = \left[1 - \left(\frac{x/2}{R} \right)^2 \right]^{1/2} = 1 - \frac{1}{2} \left(\frac{x/2}{R} \right)^2 + \frac{1}{8} \left(\frac{x/2}{R} \right)^4 + \dots \quad (4)$$

Combining Eqs. (1)–(4), we have

$$I \propto \pi R^2 \left[1 - \frac{4f}{\pi R} \theta + \frac{2}{3} \pi \left(\frac{f}{R} \right)^3 \theta^3 - \frac{2}{5} \pi \left(\frac{f}{R} \right)^5 \theta^5 + \dots \right], \quad (5)$$

where $f = 8.3 \text{ mm}$ and $R = 2 \mu\text{m}$ in our present experimental setup. Equation (5) shows that when θ is a very small angular displacement, the term $4f/(\pi R)\theta$ becomes dominate. Thus, the higher order terms in Eq. (5) can be dropped so that

$$I \propto \pi R^2 \left(1 - \frac{4f}{\pi R} \theta \right). \quad (6)$$

At our present setup, the estimated relative error introduced in this linearization process is less than 2.5% if we assume that the maximum angular displacement (θ_{max}) is $\sim 5 \times 10^{-5}$ rad. Since the output voltage ($V1$ or further V) is proportional to the intensity I , Eq. (6) can be rewritten as

$$V = k \pi R^2 \left(1 - \frac{4f}{\pi R} \theta \right), \quad (7)$$

where k is an overall proportional constant. For a given experimental setup, f , R , and k are constants so that V is a linear function of θ as long as θ is very small in comparison with the ratio of R/f ($\sim 2.4 \times 10^{-4}$).

IV. RESULTS OF CALIBRATION AND SENSITIVITY TEST

In order to calibrate our fiber optic angular displacement sensor, we mounted the mirror on a plate which can be tilted by a differential micrometer with a resolution of $0.07 \mu\text{m}$. The distance between the tip of the micrometer and the rotating center of the plate was 100 mm. Therefore, the angular resolution of this tilting device was $0.07 \mu\text{m}/100 \text{ mm}$, i.e., $\sim 10^{-6}$ rad.

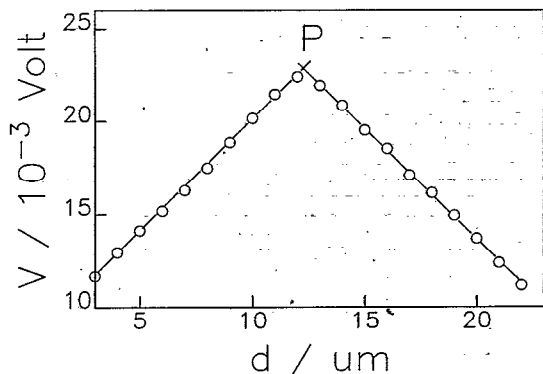

FIG. 4. Plot of V vs d , where V is only proportional to the intensity of the part of the backreflected light which has been recoupled into the fiber end and d is the position of the differential micrometer. The circles represent the measured data and the lines the least-square fits. The maximum point (P) corresponds to $V_{\max} \sim 2.3 \times 10^{-2}$ V and $x=0$ or $\theta=0$ (see the text for details).

Figure 4 shows a typical plot of V versus the displacement of the micrometer's tip (d). It can be seen in Fig. 4 that V first increases and then decreases with d . V has a maximum value ($V_{\max} \sim 2.3 \times 10^{-2}$ V). According to Fig. 3 and Eq. (7), we know that this maximum corresponds to $x=0$ or equivalently, to $\theta=0$. However, due to the experimental noise, the exact zero point of θ (or x) is not very well defined. In practice, it is much easier to measure the relative changes in θ , i.e., $\Delta\theta$, rather than to measure the absolute values of θ . According to Eq. (7), we have

$$\Delta V = k\pi R^2 \frac{4f}{\pi R} \Delta\theta = 4kfR\Delta\theta, \quad (8)$$

where $k\pi R^2 = V_{\max} \sim 2.3 \times 10^{-2}$ V, $f=8.3$ mm, and $R=2$ μm . Therefore, the estimated proportional constant ($4kfR$) in Eq. (8) is $\sim 1.22 \times 10^2$ V. In practice, the exact value of this proportional constant should be obtained by measuring ΔV as a function of $\Delta\theta$, i.e., a calibration between ΔV and $\Delta\theta$.

Figure 5 shows a typical calibration of our fiber optic angular displacement sensor. The circles represent the measured data; the line, a least-squares fit of

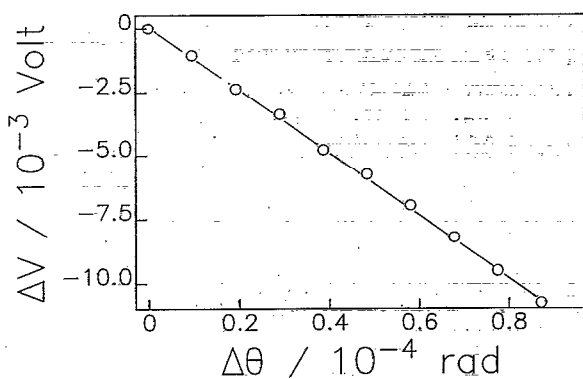

FIG. 5. Calibration of the fiber optic angular displacement sensor, where ΔV and $\Delta\theta$ are the relative changes in V and θ , respectively. The circles represent the measured data; and the line, a least-square fitting of $\Delta V = 1.19 \times 10^2 \Delta\theta$.

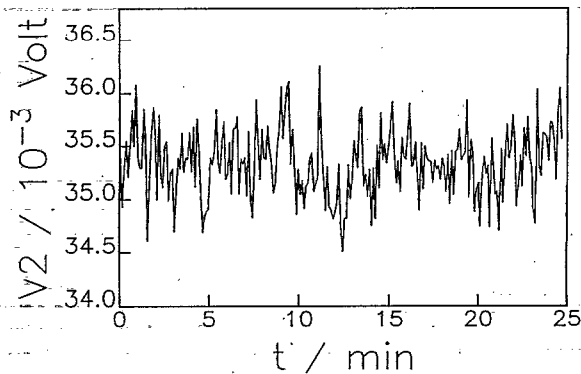

FIG. 6. Fluctuation of the light intensity, which is mainly caused by the laser light source, the temperature drift, and the vibration of the optical components in the fiber coupler (L1 in Fig. 1).

$$\Delta V = 1.19 \times 10^2 \Delta\theta, \quad (9)$$

where ΔV and $\Delta\theta$ are in the units of volt and rad, respectively. The calibration constant (1.19×10^2) in Eq. (9) is very close to the estimated value of $4kfR$ based on the value of k , f , and R , which indirectly proves the validity of Eq. (8). The maximum measurable angular displacement is $\sim 10^{-4}$ rad in our present design, which can be easily increased by using another fiber with a larger core or by using another lens with a smaller focal length. The next question we have to address is how sensitive this sensor will be, namely the angular resolution.

Figure 6 shows a plot of the fluctuation of the reference light intensity (V_2) versus the measuring time (t), where the fluctuation of V_2 is mainly caused by the laser light intensity fluctuation, the temperature drift, and the vibration of the optical components in the fiber coupler (L1 in Fig. 1). The $\sim \pm 2\%$ of relative noise in Fig. 6 is within the specifications of our He-Ne laser, which suggests that the retroreflections of light into the laser cavity have been eliminated by the optical isolator (I in Figure 1).

Figure 7 shows the stability of the measured signal (V). The noise is dominated by low frequency fluctuations and has a $\sim 6 \times 10^{-4}$ V peak-to-peak amplitude which is very

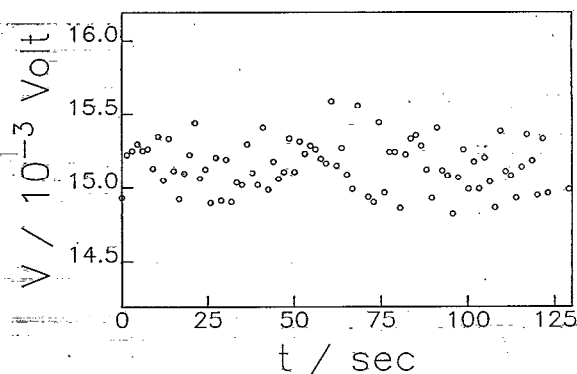

FIG. 7. Typical plot of V vs t , which shows the stability of the measured signal. The noise is dominated by low frequency fluctuations and has a $\sim 6 \times 10^{-4}$ V peak-to-peak amplitude. The rms noise of V is 1.7×10^{-4} V which corresponds to a noise of 1.4×10^{-6} rad in θ .

similar to the fluctuation in V_2 . The rms noise of V is 1.7×10^{-4} V which corresponds to a noise of 1.4×10^{-6} rad in θ according to Eq. (9). Therefore, the angular resolution of our fiber optic sensor is $\sim \pm 10^{-6}$ rad. If we use this fiber optic angular displacement sensor in a typical AFM, we will be able to detect a rms surface displacement of $\sim \pm 1$ Å, since the typical length of the cantilever is ~ 100 μm . In addition, since the reference signal (V_2) was used in our light-intensity detecting system, any drifts in the laser light intensity were canceled so that we actually observed no drift in the average value of V in a period of 1–2 h. In comparison, the drift of the output signal in the fiber optic displacement sensor (based on the interferometric principle) reported by Breen *et al.*¹ was ~ 7 Å even only in a time period of 1–2 min.

V. FURTHER IMPROVEMENTS

Several feasible improvements of this fiber optic angular displacement sensor are suggested and planned.

- (1) Use a more stable light source, such as a more stable He–Ne laser (e.g., Laboratory for Science, model 210, which has only 0.2% intensity fluctuation), an additional intensity stabilizer, or a stabilized diode laser, so that the main source of noise can be eliminated.
- (2) Modulate the incident laser light intensity and use a lock-in amplifier so that the SNR of the output signal can be improved.
- (3) Fix the fiber ends together with the couplers and the photodetectors permanently by using a refractive-index-matched glue or even by a pigtail of the optic fiber with

the light source and the detectors so that both the temperature and vibration drifts can be reduced.

- (4) Replace the microscope objective lens with a small gradient-index lens (typically, 1–2 mm in diameter and 3–5 mm in length) so that the head of the sensor can be reduced.
- (5) Use two single-mode fibers instead of a four-port coupler. One fiber would be for sending the light and the other one for receiving the reflected light. These two fibers are placed symmetrically about the optical axis of the lens (L2 in Fig. 1). In this way, the optical isolator can be removed. However, this setup requires a stable light source since there is no reference signal V_2 in this configuration.
- (6) After accomplishing the above improvements, it is expected that the noise will be reduced and the detection limit can be pushed down to subangstrom (< 1 Å).

ACKNOWLEDGMENT

The partial financial support of this work by the RGC (the Research Grants Council of Hong Kong Government) Earmarked Grant 1993/94 (CUHK 79/93E, 221600140) is gratefully acknowledged.

¹S. Breen, B. E. Paton, B. L. Blackford, and M. H. Jericho, *Appl. Opt.* **29**, 16 (1990), and references therein.

²D. Rugar, H. J. Mamin, R. Erlandsson, J. E. Stern, and B. D. Terris, *Rev. Sci. Instrum.* **59**, 2337 (1988).

³D. Rugar and P. Hansma, *Physics Today*, October, 23 (1990).

⁴B. Culshaw, *Optical Fibre Sensing and Signal Processing* (Peregrinus, London, 1984).