



# 【萬有理論】

A Theory of Everything  
*by Ken Wilber*

黃永

2010.03.05



# 黃永

垂直思考

水平思考

**2007至今**  
擔任商業一台雷霆881節目  
《在晴朗的一天出發》主持  
及出任商業電台策劃總監。

**2003 - 2006**  
主力公共事務及  
政策研究工作。

**2002 - 2003**  
獲倫敦大學法律學位，  
並協助智庫研究  
公私營合作政策。

**2001 - 2002**  
負笈英國劍橋大學深造，  
獲取工商管理碩士學位。  
研究創意思考之論文，  
贏得巴克萊最佳碩士論文獎。

**1998 - 2000**  
加入政府當政務主任，  
曾主理福利及城市規劃。

**1996 - 1998**  
加入香港奧美廣告。

**1994 - 1996**  
於多倫多大學修讀經濟。  
期間熱愛舞台製作，並創立  
首個全國性華人辯論比賽。



# Development Phases of Ken Wilber

- Phase 1 (1977-1979): Romantic-Jungian – Consciousness as a spectrum growth and a return to a non-dualistic condition.



- Phase 2 (1980-1982): Mystical attainment – Pop-Tibetan Buddhist-inspired cycle of involution-evolution.



- Phase 3 (1983-1987): Developmental lines – A complex process consisting of distinct lines (cognitive, emotional, social, spiritual) proceeding independently.

- Crisis (1987 – 1989) → *Grace & Grit*

- Hibernation (1989 – 1994)



- Phase 4 (1995-Now): "*All Quadrants All Levels*" Model – Founded the Integral Institute (2001) and the Integral University (2008)



# Ken Wilber & Integral Theory

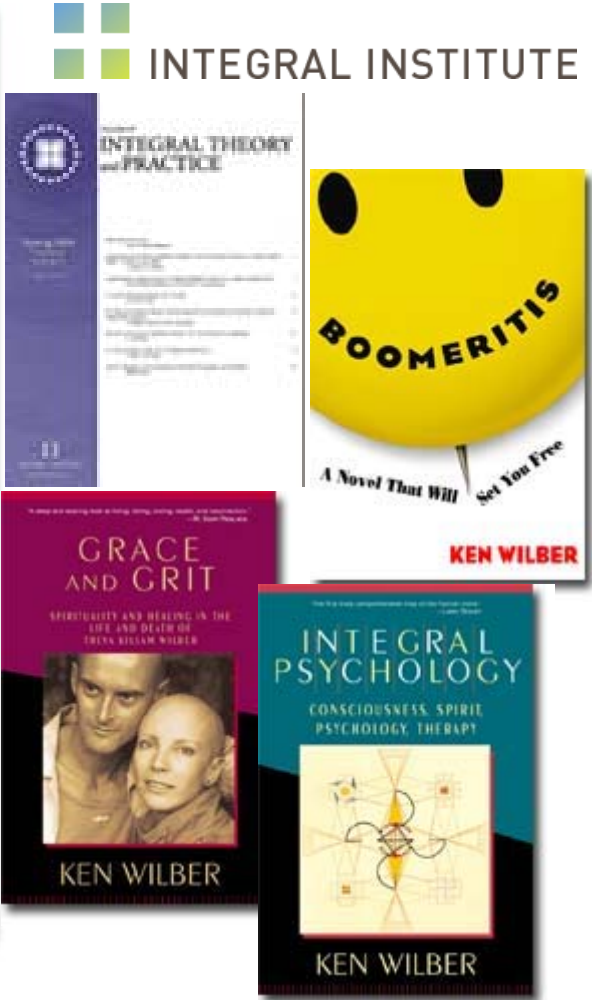
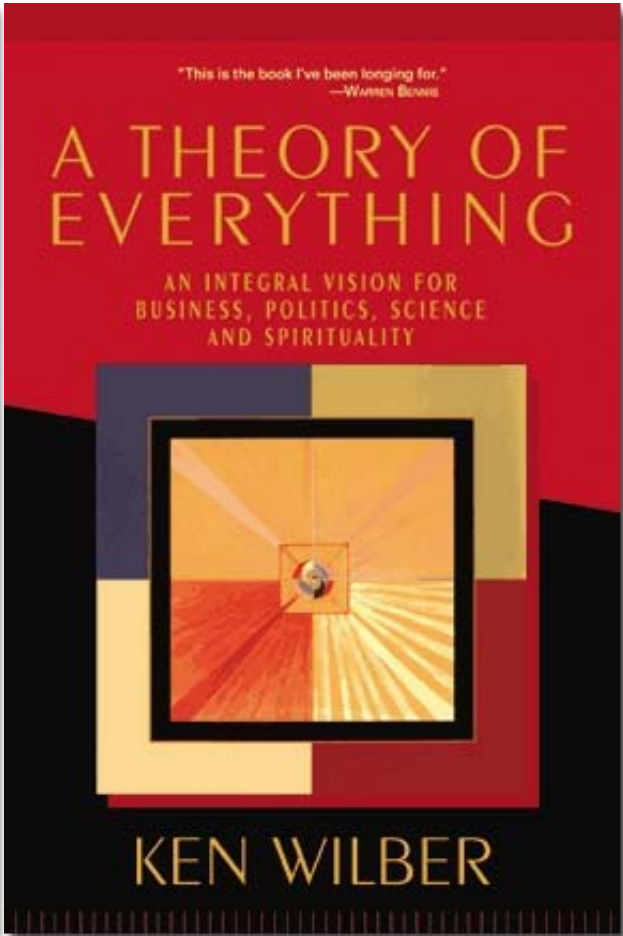
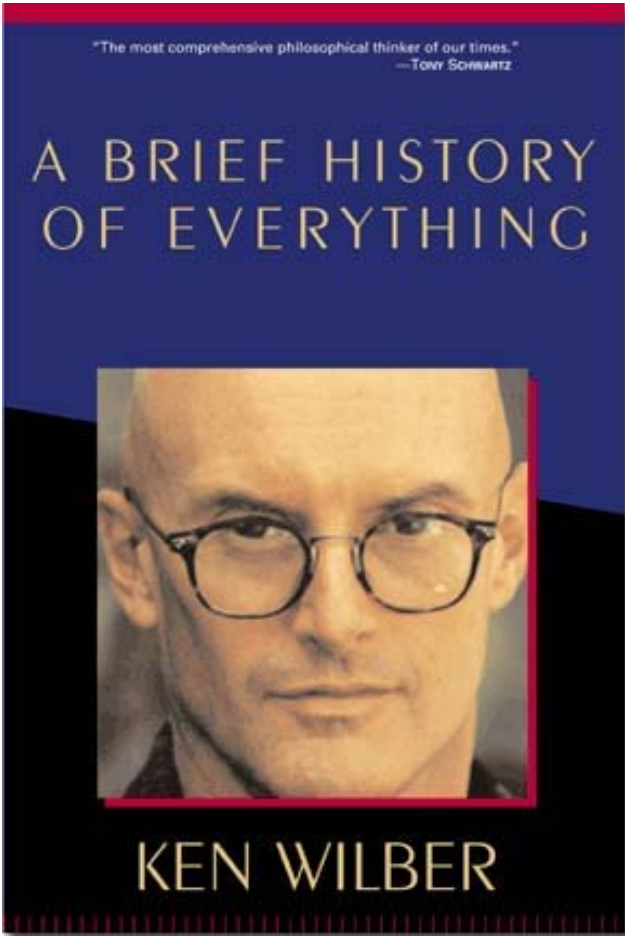

# 理論 THEORY

- 簡化了的世界，一個模型。
- 存在「能證明其錯」之空間
- 超理論 Meta-Theory
- 萬有理論 Theory of Everything (ToE)
- 例：
  - 牛頓三大定律  $F = ma$  (日、月、星、地)
  - 愛因斯坦相對論  $E = mc^2$  (光與暗)
  - 霍金時間簡史  $\alpha \rightarrow \Omega$  (混沌、起初、末日)



# 萬「物」理論 A ToE for Physics

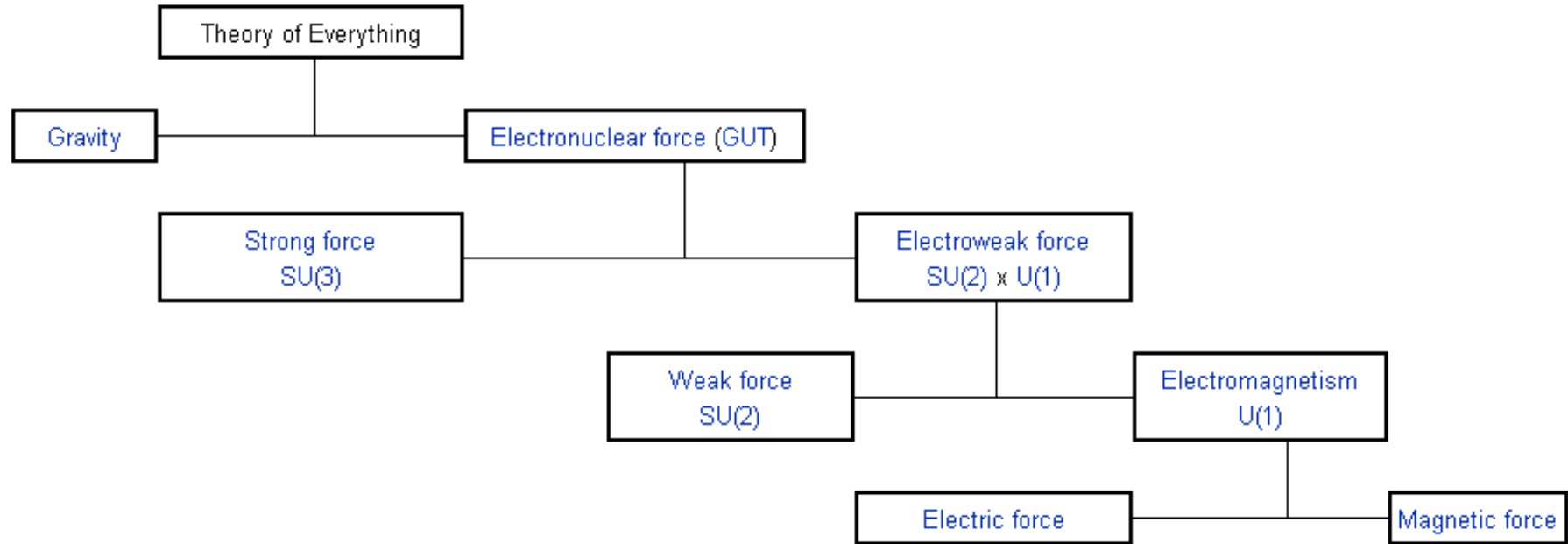

- 牛頓三大定律  $F = ma$  (日、月、星、地)
- 愛因斯坦相對論  $E = mc^2$  (光與暗)
- 霍金時間簡史  $\alpha \rightarrow \Omega$  (混沌、起初、末日)



# Fundamental Framework for a ToE

→ AQAL: All Quadrants All Levels

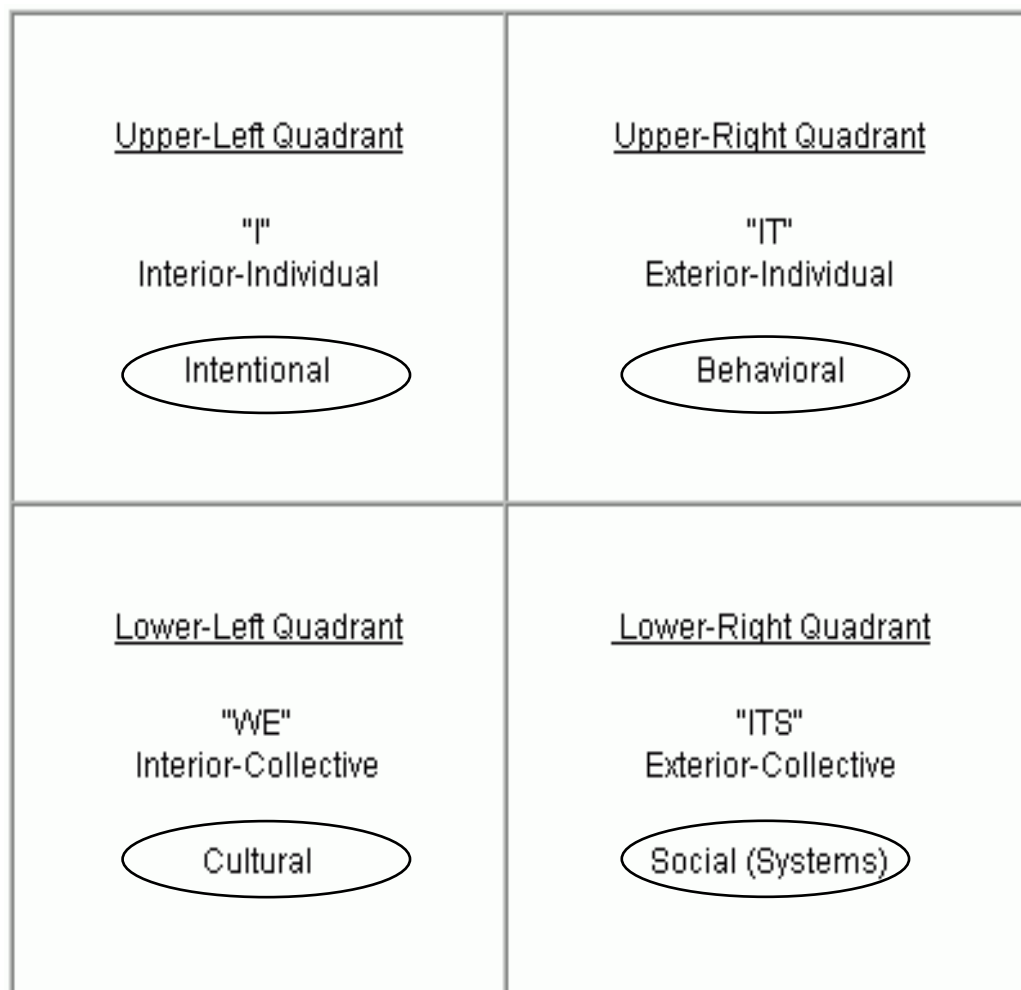

# Types under the AQAL Framework

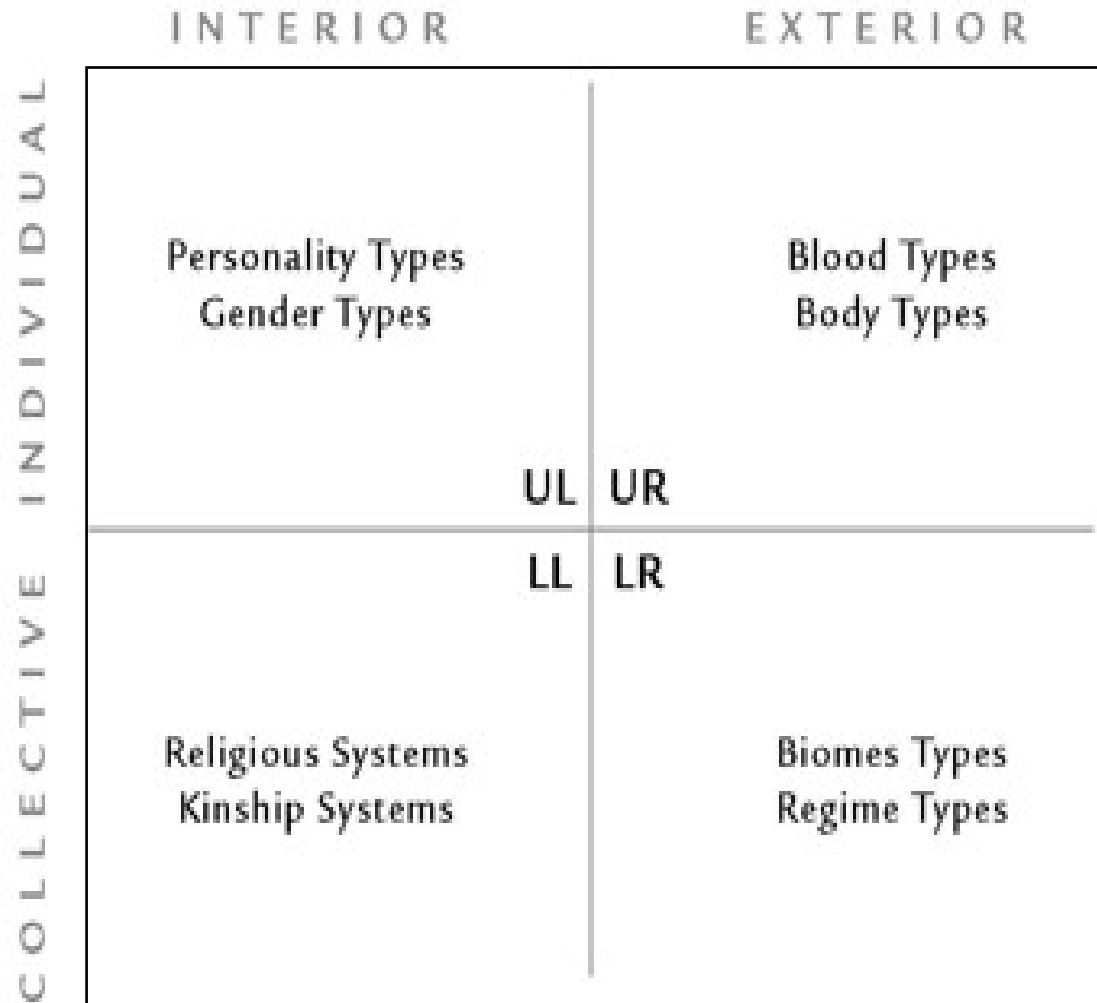



# Different Types of Fit in the ToE

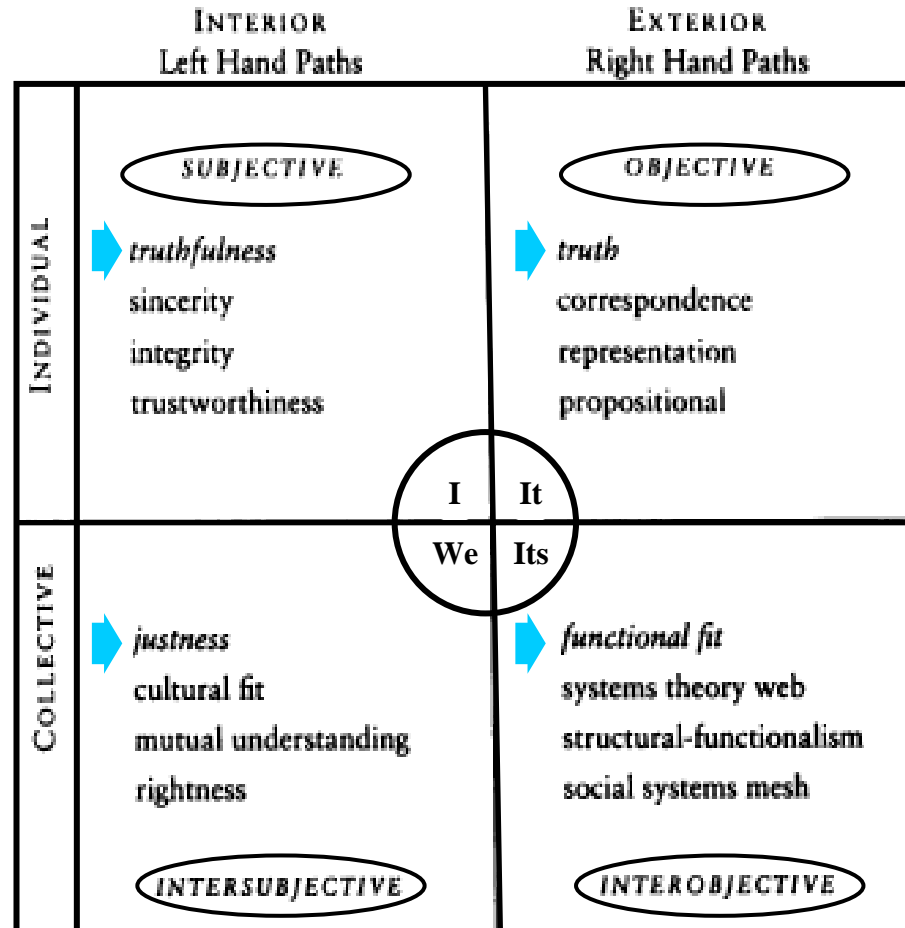

兩類主要理論模型：

# 動與靜 → 進化 VS 分類

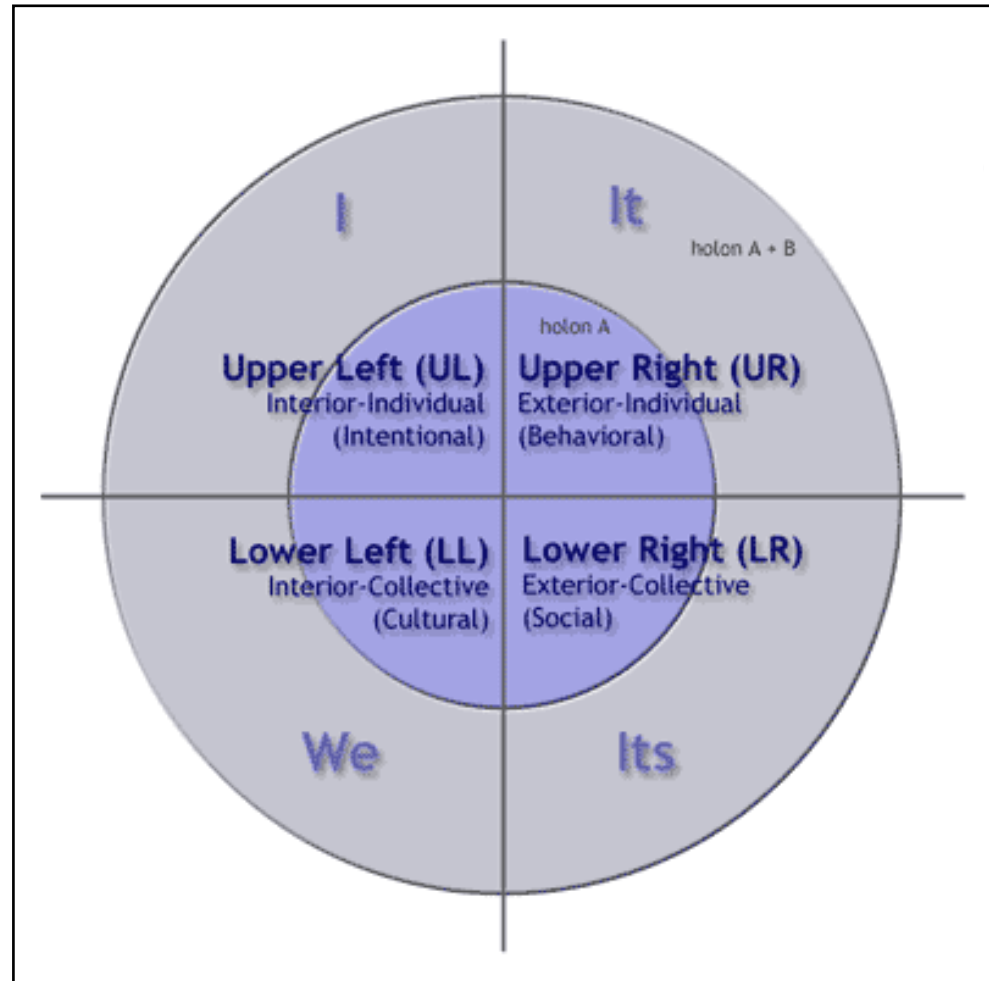

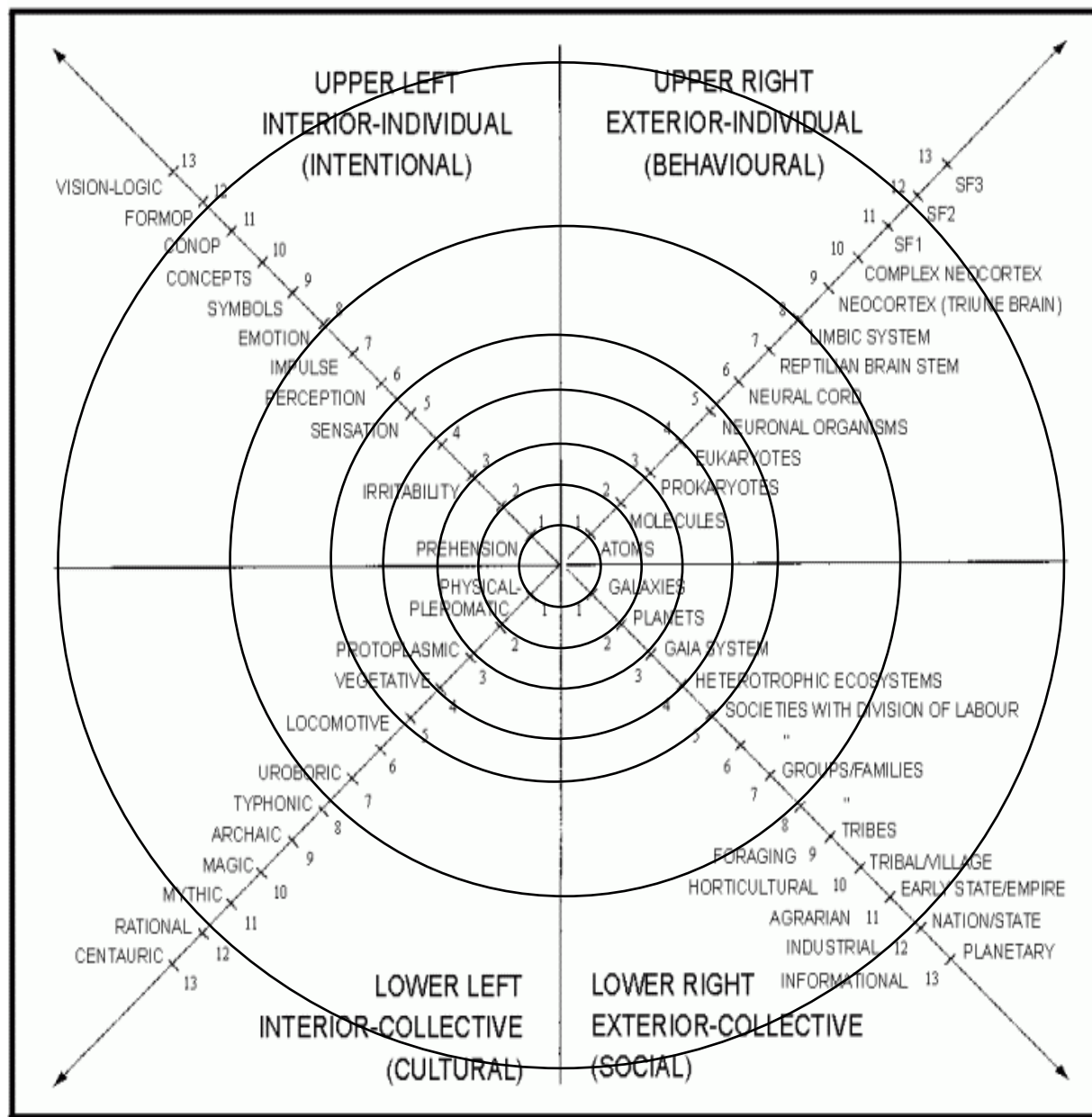

# Development Lines under AQAL

	INTERIOR	EXTERIOR
INDIVIDUAL	Cognitive awareness Emotional access Interpersonal skills Psychosexual expression Moral capacity Spiritual experience Self-identity dynamics	Organic structures Neuronal systems Neurotransmitters Brainwave patterns Skeletal-muscular growth Nutritional intake Kinesthetic capacity
	UL	UR
COLLECTIVE	Worldviews Intersubjective dynamics Linguistic meaning Cultural values Background cultural contexts Philosophical positions Religious understandings	Forces of production Geopolitical structures Ecosystems Written legal codes Architectural styles Grammatical systems Evolutionary paths
	LL	LR



# 萬有理論

- 可以是一套理念
- 可永遠持續發展
- 可指導思考方向
- 可成爲分析方法
- 可尋找理論盲點
- 可增進記憶能力
- 可協助公眾諮詢
- 可用來調配資源

綜  
*INTEGRAL*  
合



# 綜合 INTEGRAL

- 綜合政治 INTEGRAL POLITICS
- 綜合醫治 INTEGRAL MEDICINE
- 綜合教育 INTEGRAL EDUCATION
- 綜合管理 INTEGRAL MANAGEMENT



# 綜合政治 INTEGRAL POLITICS

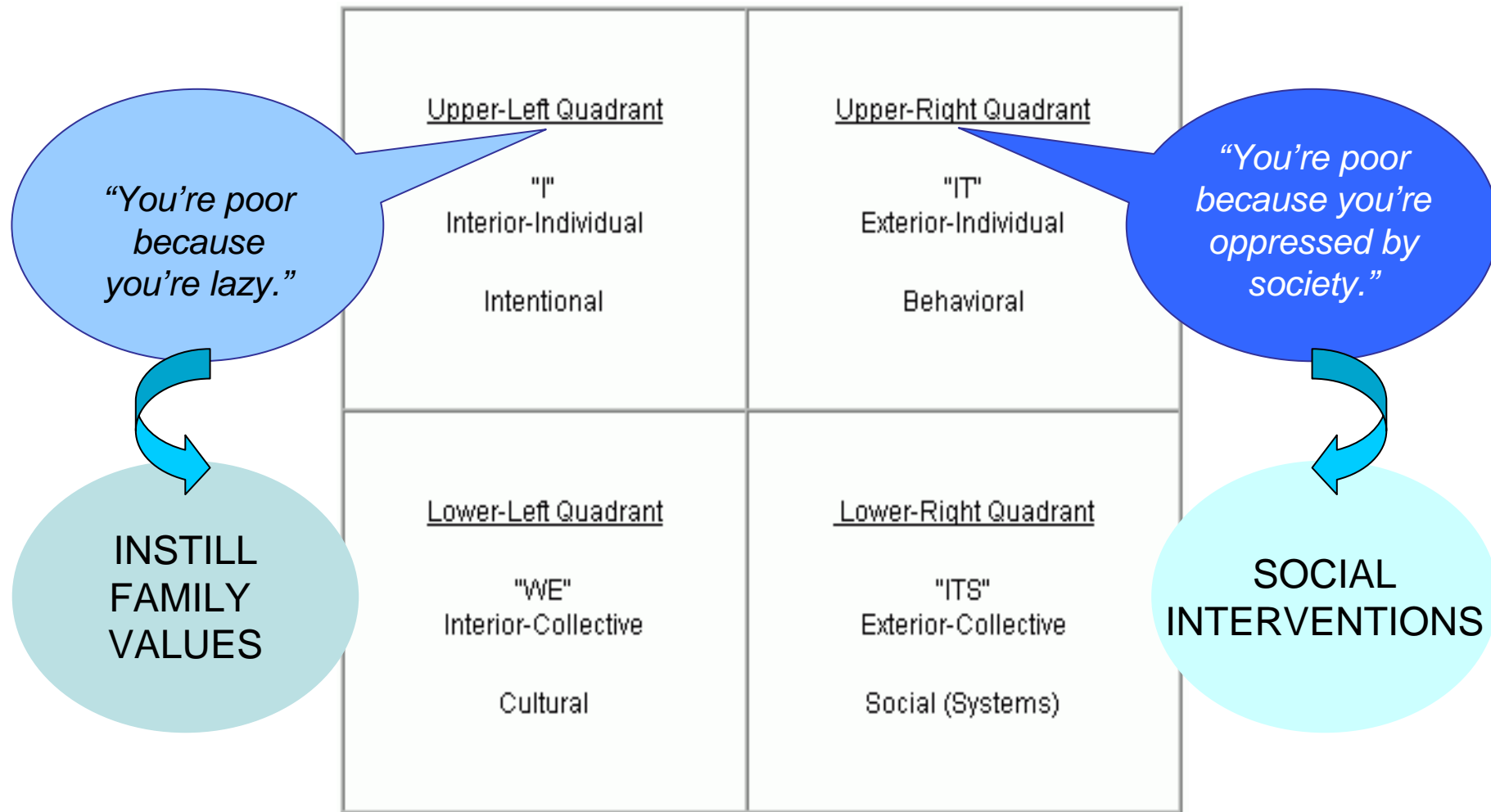

# ToE for Urban Planning

→ From Existing Land to Open Space

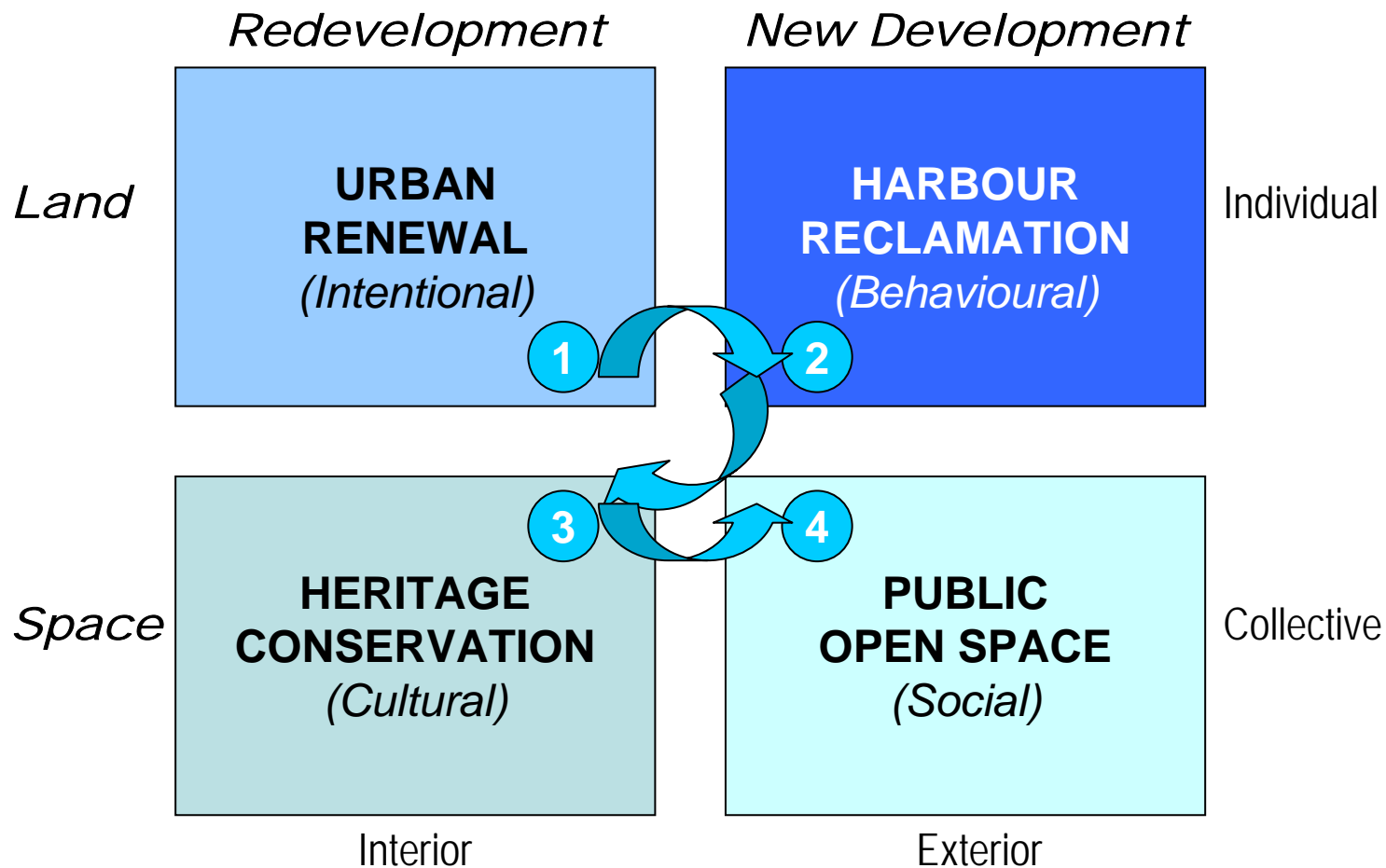



# 綜合醫治 INTEGRAL MEDICINE

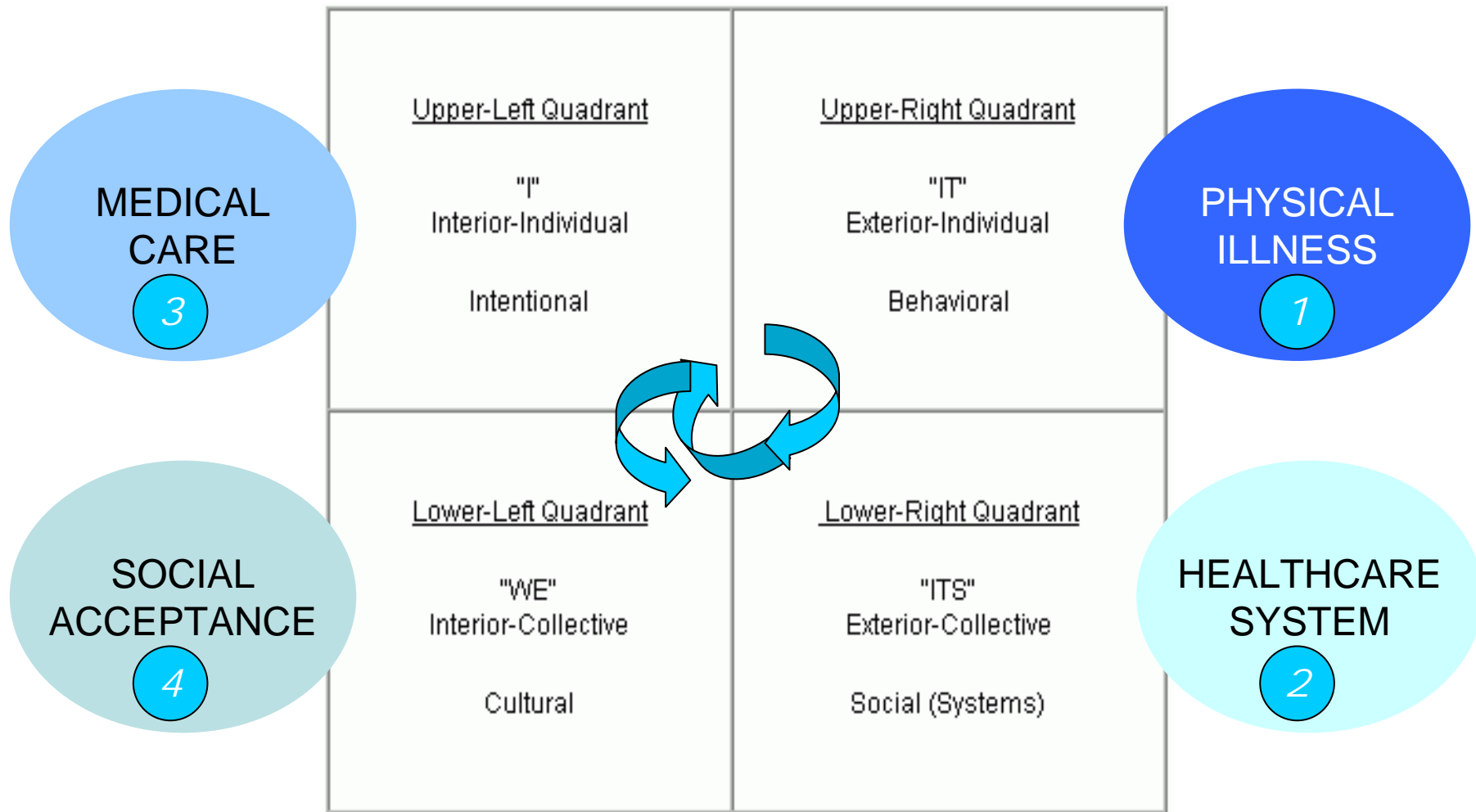

# 綜合教育 INTEGRAL EDUCATION

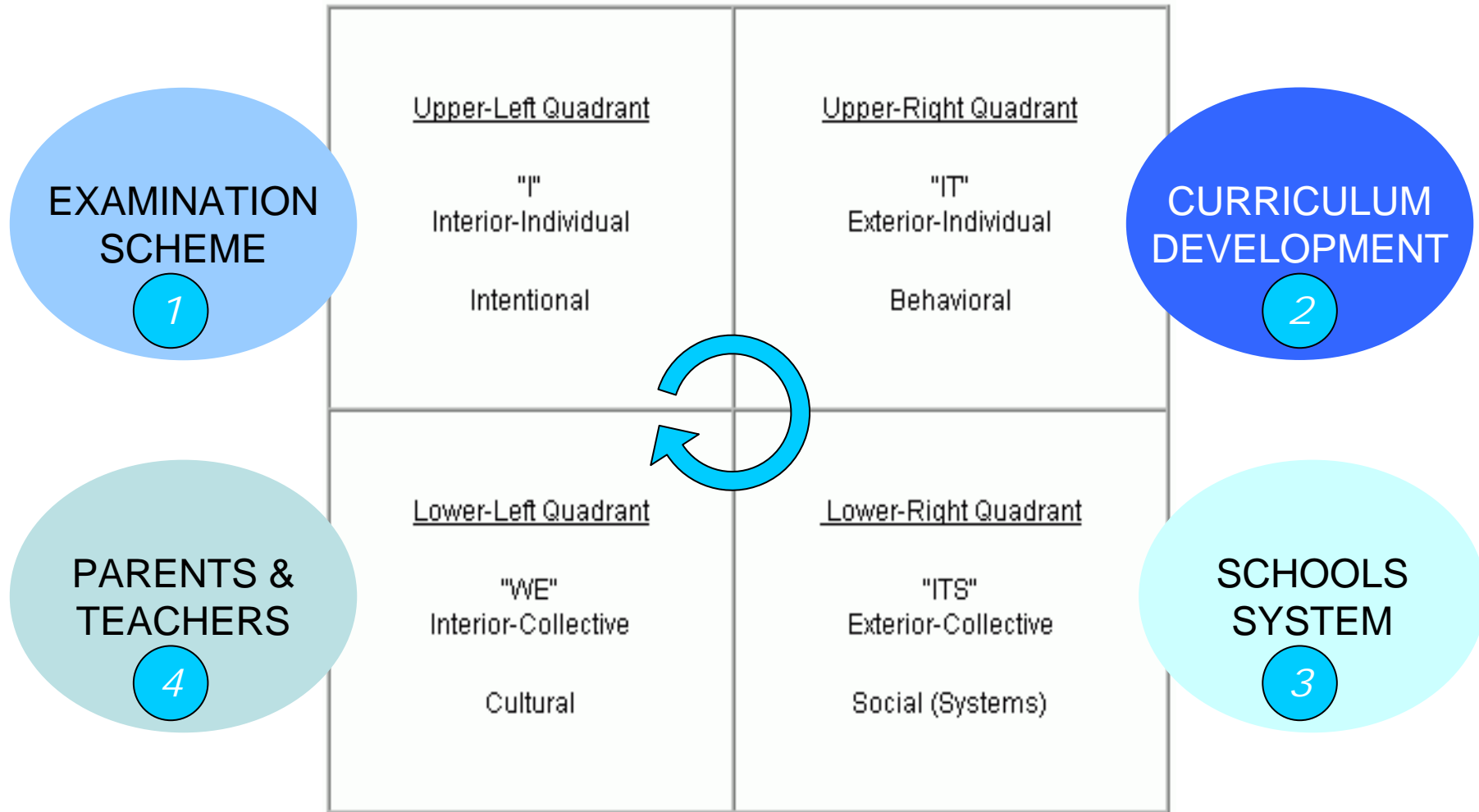

# 綜合管理 INTEGRAL MANAGEMENT

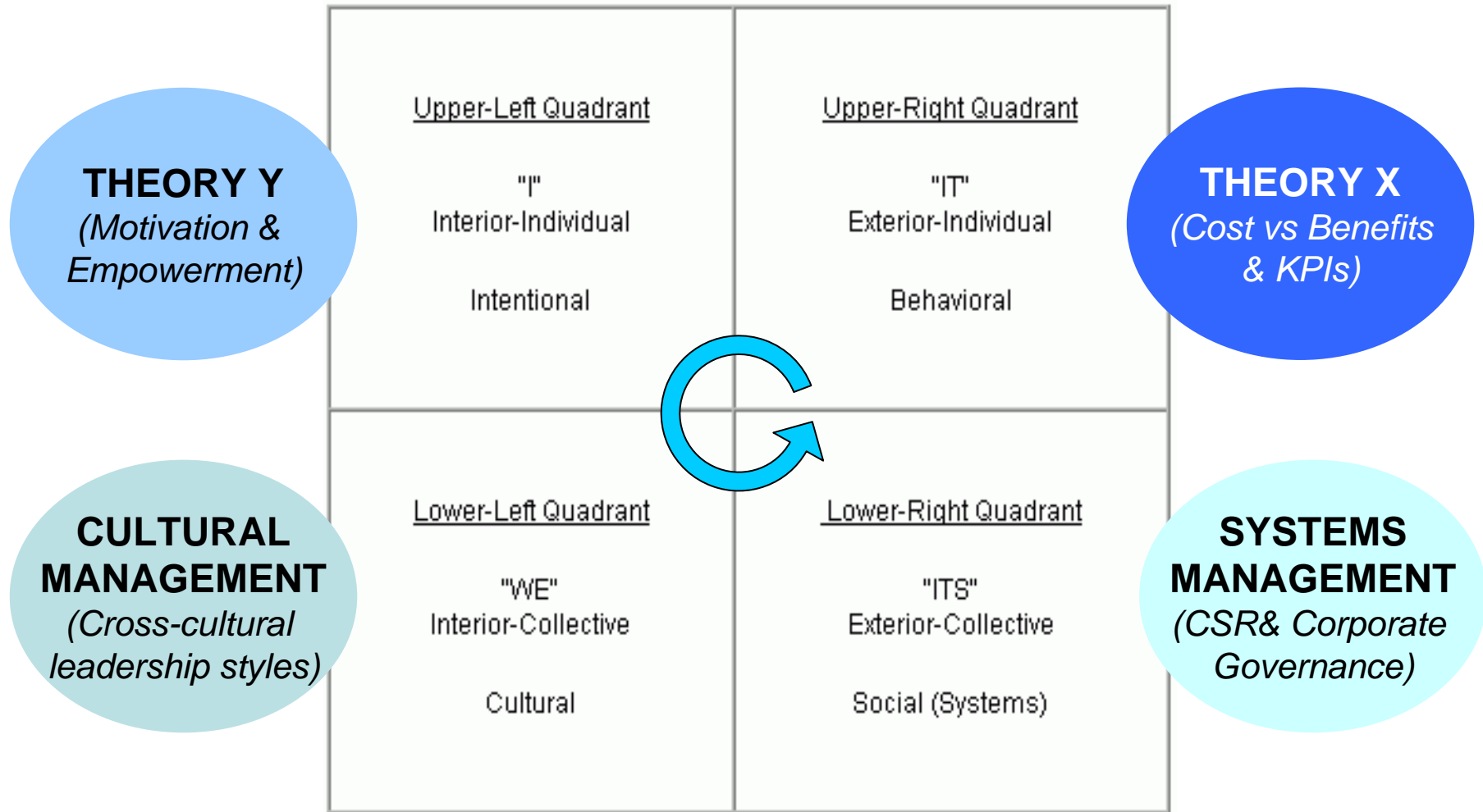

# FURTHER READING

→ A ToE for the Book Club?

*S. Freud  
C. G. Jung  
Gautama Bhaddha  
Piaget  
Plotinus*

Upper-Left Quadrant

"I"  
Interior-Individual  
Intentional

Upper-Right Quadrant

"IT"  
Exterior-Individual  
Behavioral

*B. F. Skinner  
John Locke  
Empiricism  
Physics  
Biology*

*Thomas Kuhn  
Max Weber  
Wilhelm Dilthey  
Jean Gebser  
H.-G. Gadamer*

Lower-Left Quadrant

"WE"  
Interior-Collective  
Cultural

Lower-Right Quadrant

"ITS"  
Exterior-Collective  
Social (Systems)

*Karl Marx  
Talcott Parsons  
Gerhard Lenski  
Systems Theory  
Social Ecology*

