



香港中文大學
The Chinese University of Hong Kong

CENG4480

Lecture 05: Sensors

Bei Yu

byu@cse.cuhk.edu.hk
(Latest update: October 12, 2017)

Fall 2017

Overview

1. Motion Sensors

- 1-1. Accelerometer
- 1-2. Gyroscope
- 1-3. Compass
- 1-4. Tilt Sensor

2. Force Sensors

- 2-1. Force Sensing Resistor
- 2-2. Strain Gauge
- 2-3. Flexion (bend) sensors
- 2-4. Air Pressure Sensor

3. Other Sensors

- 3-1. Position sensors
- 3-2. Temperature and humidity
- 3-3. Optical Sensors
- 3-4. Hall Effect Sensors
- 3-5. Kinect Sensors



Overview

1. Motion Sensors

1-1. Accelerometer

1-2. Gyroscope

1-3. Compass

1-4. Tilt Sensor

2. Force Sensors

2-1. Force Sensing Resistor

2-2. Strain Gauge

2-3. Flexion (bend) sensors

2-4. Air Pressure Sensor

3. Other Sensors

3-1. Position sensors

3-2. Temperature and humidity

3-3. Optical Sensors

3-4. Hall Effect Sensors

3-5. Kinect Sensors



1-1. Accelerometer

- ▶ Electromechanical devices that sense
 - ▶ **Static** acceleration (gravity)
 - ▶ **Dynamic** acceleration (vibrations & movement)
- ▶ Functions:
 - ▶ measure acceleration in one or more directions, position can be deduced by integration.
 - ▶ Orientation sensing: tilt sensor
 - ▶ Vibration sensing
 - ▶ measure acceleration in one or more directions, position can be deduced by integration.
- ▶ Methods:
 - ▶ **Mass spring** method ADXL78 (from Analog Device)
 - ▶ **Air pocket** method (MX2125)



ADXL78 (Mass Spring Method)

- ▶ Click this [online document](#)
- ▶ Measure the capacitance to create output
- ▶ Measure both dynamic & static acceleration

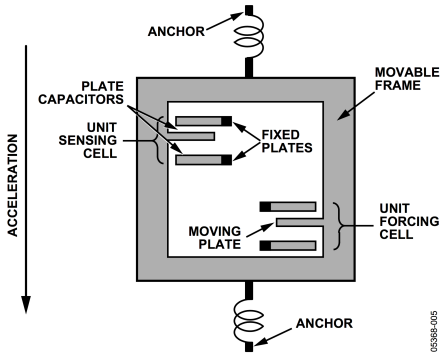

Figure 5. Simplified View of Sensor Under Acceleration

05368-005

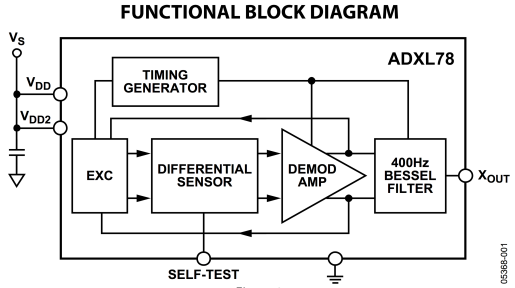

Figure 1.

05368-001



ADXL330 Accelerometer for (X, Y, Z) Directions

- ▶ Klik this [online document](#)
- ▶ 3D

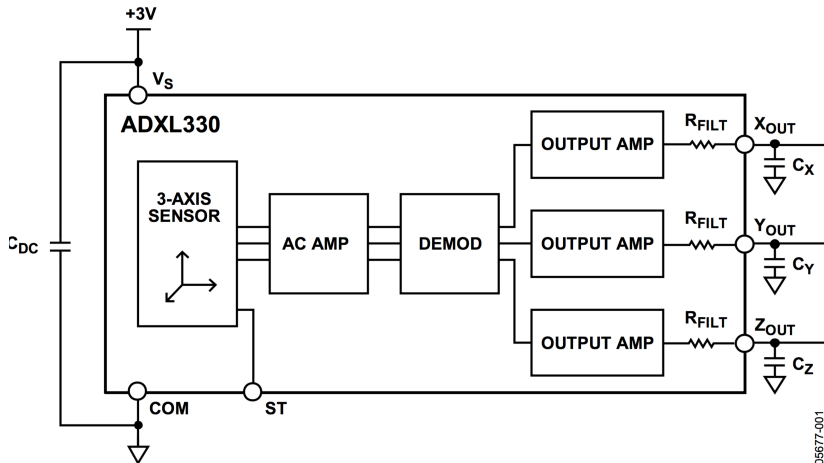

Figure 1.



2D Translational Accelerometer MX2125



Accelerometer Module

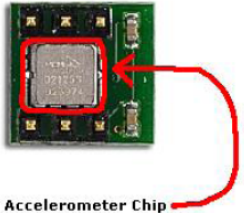

Accelerometer Chip

- ▶ Click this [online document](#)
- ▶ Gas pocket type

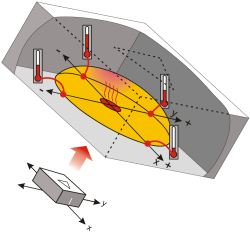
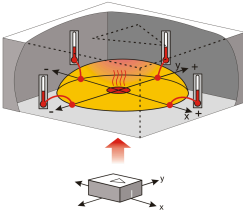

- ▶ When the sensor moves, the temperatures of the 4 sensors are used to evaluate the 2D accelerations



Demo: orientation sensing

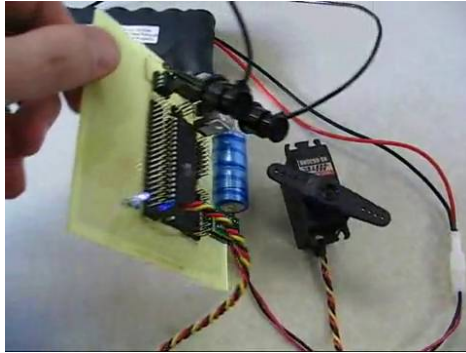

(<http://www.youtube.com/watch?v=9NEiBDBXFEQ>)



1-2. Gyroscopes

- ▶ [wiki page](#)
- ▶ Measure rotational angle

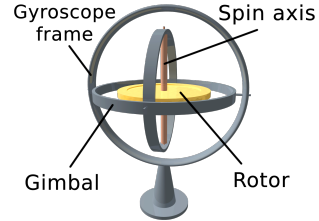

Rate Gyroscope

- ▶ Measure the rate of rotation along 3-axes of X (pitch), Y (roll), and Z (yaw).
- ▶ Modern implementations are using Microelectromechanical systems (MEMS) technologies.



Gyroscope to Measure Rational acceleration

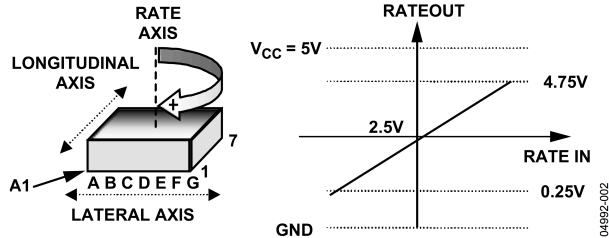

Figure 2. RATEOUT Signal Increases with Clockwise Rotation

Features

- ▶ Complete rate gyroscope on a single chip Microelectromechanical systems (MEMS)
- ▶ Z-axis (yaw-rate) response

Applications

- ▶ GPS navigation systems
- ▶ Image stabilization
- ▶ Inertial measurement units
- ▶ Platform stabilization



1-3. Compass

- ▶ Philips KMZ51 magnetic field sensor
- ▶ 50/60Hz (high) operation, a jitter of around 1.5°

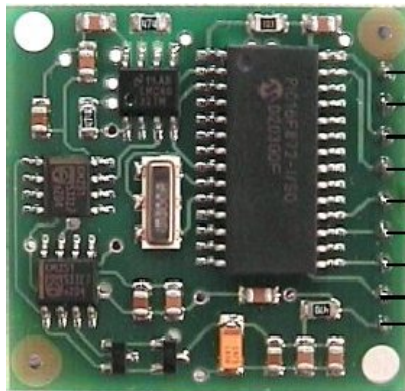

- Pin 9 - 0v Ground
- Pin 8 - No Connect
- Pin 7 - 50/60Hz
- Pin 6 - Calibrate
- Pin 5 - No Connect
- Pin 4 - PWM
- Pin 3 - SDA
- Pin 2 - SCL
- Pin 1 - +5v



Rate gyroscope demo

Using Gyroscope compass for virtual reality application in an iphone

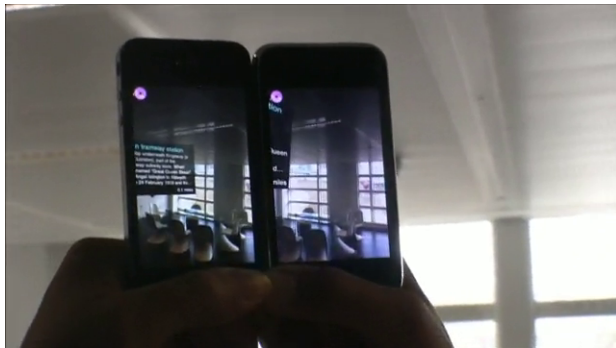

(<http://www.youtube.com/watch?v=VP4-wdMMLFo>)



1-4. Tilt Sensor by OMRON

- ▶ Click this [online document](#)
- ▶ Detect tilting 35 ~ 65 degrees in right-and-left inclination

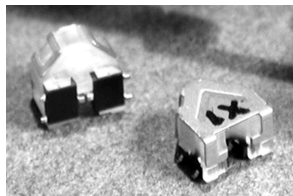
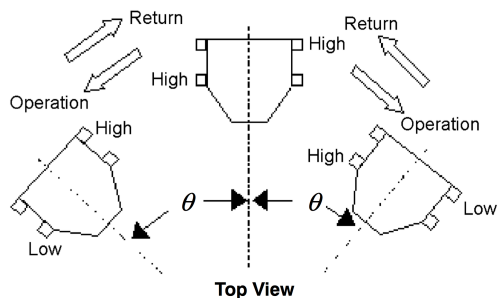

Gravity
direction

- Note: 1. Operation angle: Output goes from High to Low
2. Return angle: Output goes from Low to High



Demo: Tilt Sensing



(<http://www.youtube.com/watch?v=C6uVrYz-j70>)

One more reference: <https://www.youtube.com/watch?v=KZVgKu6v808>.



Application – Self Balancing Robot

20cm

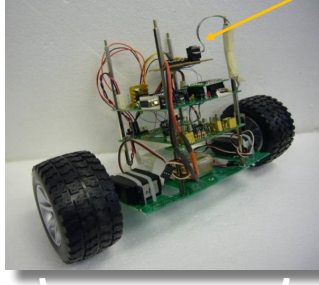

Motion sensors:
gyroscope and
accelerometer

35cm

by Kelvin Ko (<http://hk.youtube.com/watch?v=2u-E02FDFG0>)



Complementary Filter

- ▶ Since

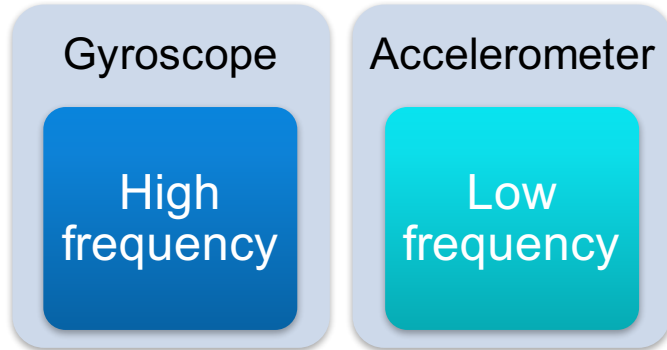

- ▶ Combine two sensors to find output



Complementary Filter (cont.)

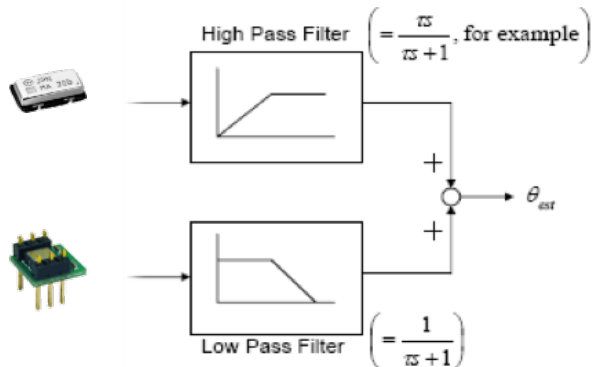

- ▶ θ : rotation angle
- ▶ τ : filter time constant
- ▶ s : Laplace operator



Overview

1. Motion Sensors

- 1-1. Accelerometer
- 1-2. Gyroscope
- 1-3. Compass
- 1-4. Tilt Sensor

2. Force Sensors

- 2-1. Force Sensing Resistor
- 2-2. Strain Gauge
- 2-3. Flexion (bend) sensors
- 2-4. Air Pressure Sensor

3. Other Sensors

- 3-1. Position sensors
- 3-2. Temperature and humidity
- 3-3. Optical Sensors
- 3-4. Hall Effect Sensors
- 3-5. Kinect Sensors



2-1. Force Sensing Resistors

- ▶ FSR402
- ▶ Click [this online document](#)

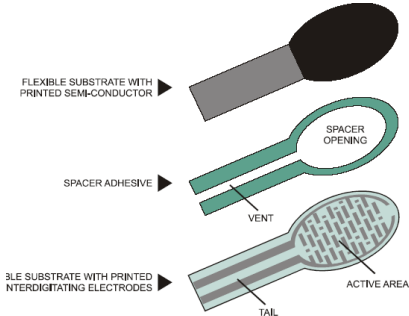
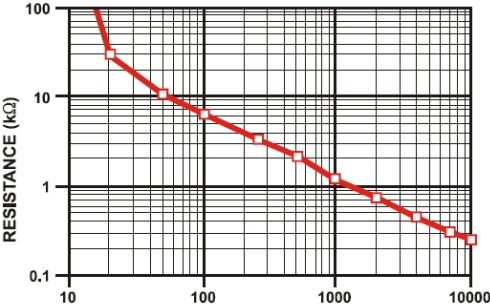
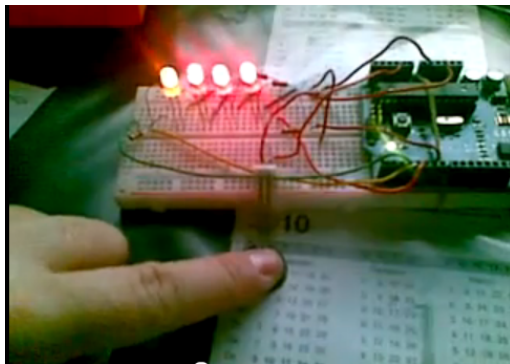

Figure 1: FSR Construction



Force Sensing Resistor Demo



(<http://www.youtube.com/watch?v=LQ211Xr6egs>)

Application 1: Walking Robot

- ▶ Balancing

Neutral position



Floor tilted left
upper leg bend right



Floor tilted right
upper leg bend left



Four sensors under the foot



Four Force sensors under the foot

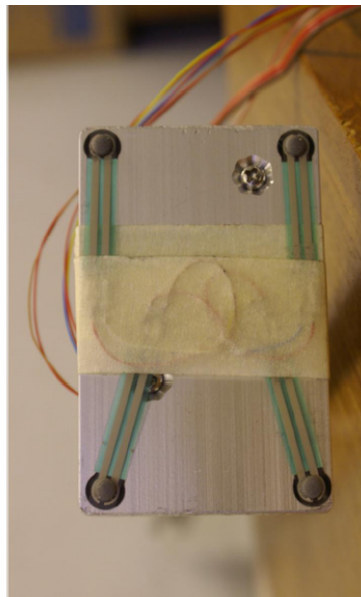
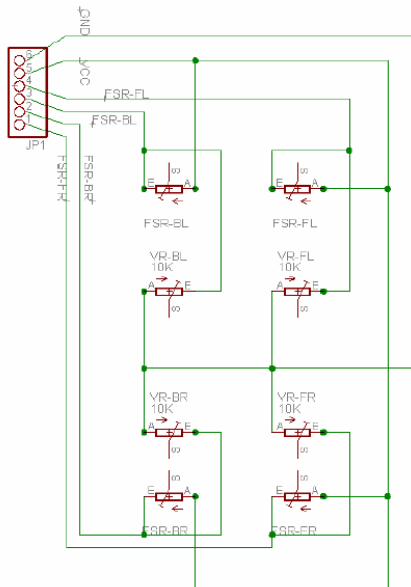

Application 2: The Nao Robot

- ▶ uses force feedback at its feet
- ▶ [wiki page](#)



(<https://www.youtube.com/watch?v=2STTNYNF41k>)



Application 3: Robot Dog from Boston Dynamics

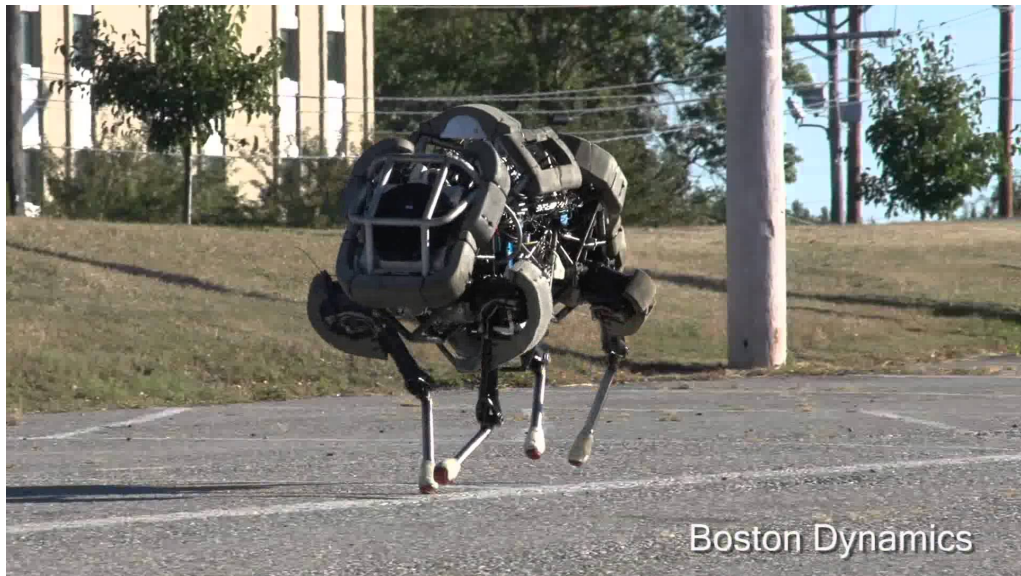

(<https://www.youtube.com/watch?v=NtU9p1VYtcQ>)



2-2. Strain Gauge

What's Strain?

Amount of deformation of a body due to an applied force.

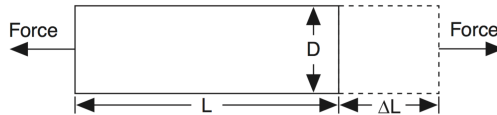

$$\epsilon = \frac{\Delta L}{L}$$

Figure 1. Definition of Strain



Strain Gauge (cont.)

- ▶ **Piezoelectric crystal:** produces a voltage that is proportional to force applied
- ▶ **Strain gauge:** cemented on a rod. One end of the rod is fixed, force is applied to the other end. The resistance of the gauge will change with the force.

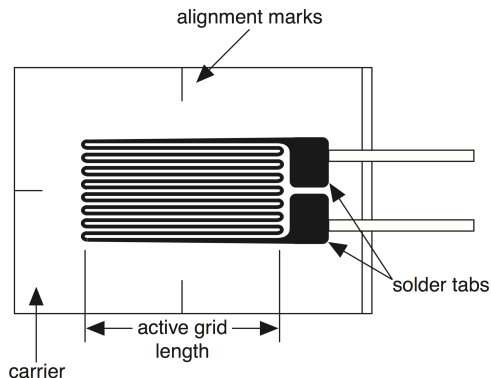

Strain Gauge (cont.)



Ex: mechanical strain gauge used to measure the growth of a crack in a masonry foundation.

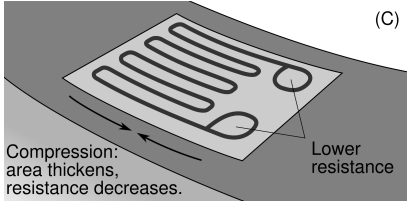
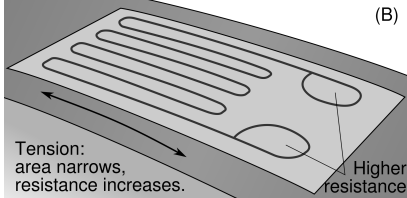
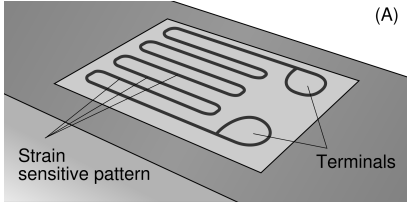

Wheatstone Bridge

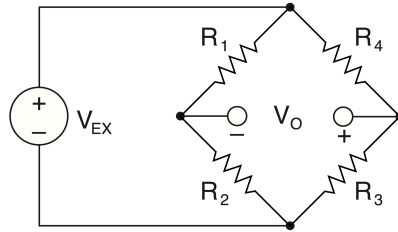

Wheatstone Bridge

$$V_O = \left[\frac{R_2}{R_1 + R_2} - \frac{R_3}{R_3 + R_4} \right] \cdot V_{EX}$$



Single Element Strain Gauge

Sensitive to temperature change.

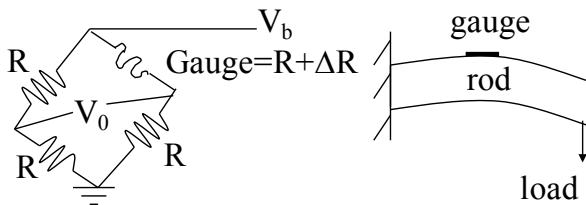

Out Voltage

$$V_0 = \left[\frac{R}{2R} - \frac{R}{2R + \Delta R} \right] \cdot V_b = \left[\frac{\Delta R}{4R + 2\Delta R} \right] \cdot V_b$$
$$\approx \frac{\Delta R}{4R} \cdot V_b$$



Four-Element Strain Gauge

- ▶ **Four times more sensitive** than single gauge system
- ▶ **NOT sensitive** to temperature change.
- ▶ All gauges have unstrained resistance R .

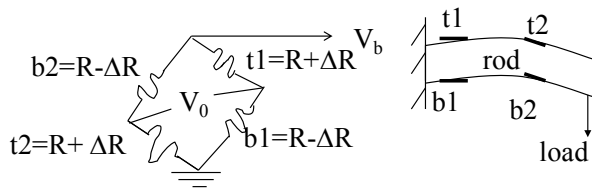

Question

For four-element strain gauge, calculate $\frac{V_O}{V_b}$.

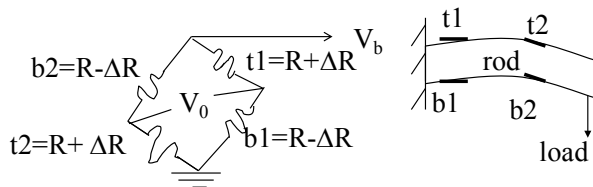

2-3. Flexion (bend) sensors

Resistance:

- ▶ $10\text{ K}\Omega$ (0°);
- ▶ $30\text{--}40\text{ K}\Omega$ (90°)

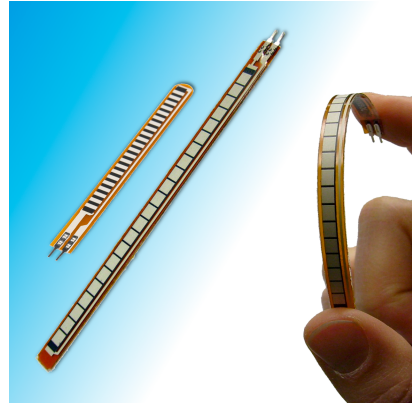

<https://www.youtube.com/watch?v=1EUV1SsAhCg>

Click this [online document](#)



Felixon resistance Demo

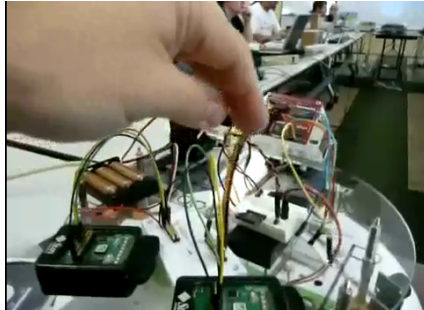

(<http://www.youtube.com/watch?v=m4E5SP7HCnk&feature=related>)



2-4. Air Pressure Sensor

- ▶ Measure up to 150 **psi** (pressure per square inch).

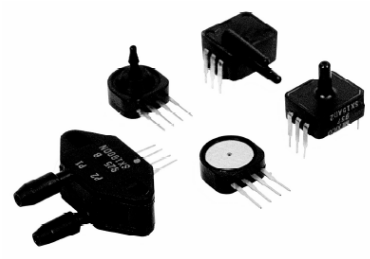

Overview

1. Motion Sensors

- 1-1. Accelerometer
- 1-2. Gyroscope
- 1-3. Compass
- 1-4. Tilt Sensor

2. Force Sensors

- 2-1. Force Sensing Resistor
- 2-2. Strain Gauge
- 2-3. Flexion (bend) sensors
- 2-4. Air Pressure Sensor

3. Other Sensors

- 3-1. Position sensors
- 3-2. Temperature and humidity
- 3-3. Optical Sensors
- 3-4. Hall Effect Sensors
- 3-5. Kinect Sensors



Infra-red Range detectors

- ▶ by SHARP (4 to 30 cm)
- ▶ An emitter sends out light pulses. A small linear CCD array receives reflected light.
- ▶ The distance corresponds to the triangle formed.

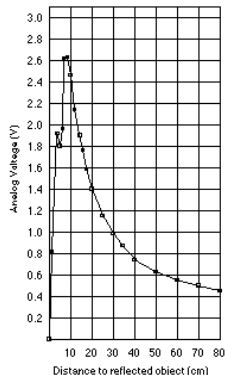
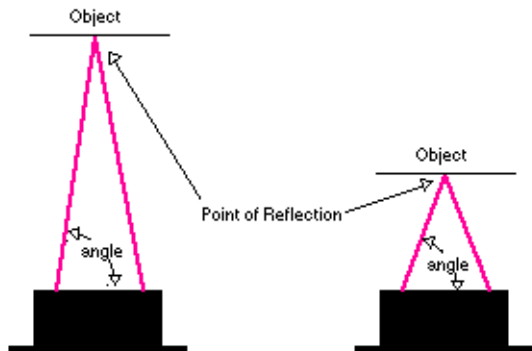

<http://www.acroname.com/robotics/info/articles/sharp/sharp.html>



IR radar using the Sharp range detector

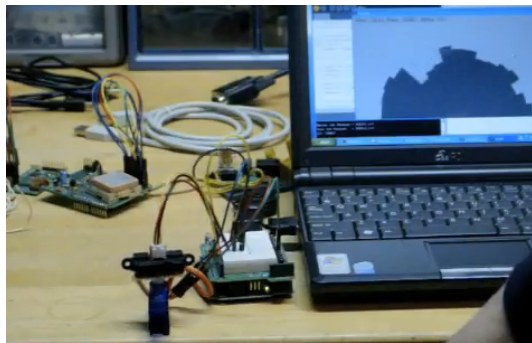

<http://www.youtube.com/watch?v=tStBLAiQaC8&feature=related>



Position Sensors

- ▶ Rotary

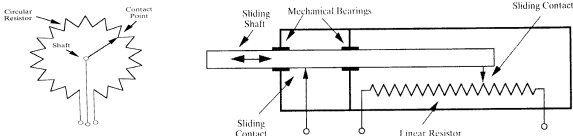

- ▶ Rotary Encoder

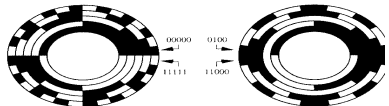

- ▶ Digital Linear Encoder



Optical Rotary Encoder

- ▶ [wiki page](#)
- ▶ <https://www.youtube.com/watch?v=RuIislTGOWA>
- ▶ The light received (on or off) will tell the rotation angle)

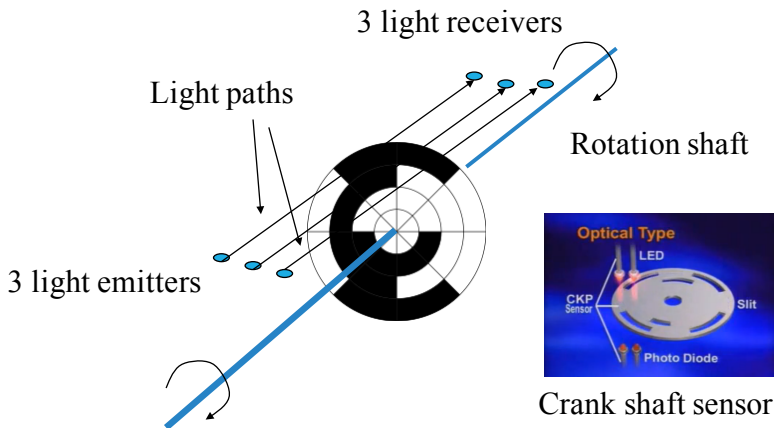

Magnetic rotary encoder

- ▶ Check the [online info](#)
- ▶ Non touch sensing



Humidity Sensor

- ▶ Check the [online document](#)
- ▶ Humidity range (RH) -> Capacitance
- ▶ BCcomponents 2322 691 90001: 10–90%RH Dc

QUICK REFERENCE DATA

PARAMETER	VALUE	UI
Humidity range (RH)	10 to 90	%
Capacitance at +25 °C; 43% RH; 100 kHz	122 ±15%	pF
Sensitivity between 12 and 75% RH	0.4 ±0.05	pF/%
Frequency	1 to 1000	kHz
Maximum AC or DC voltage	15	V

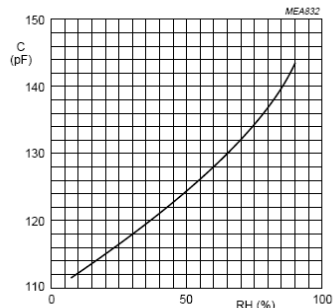
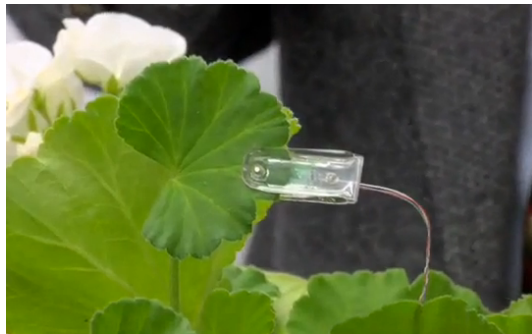

Fig.2 Typical capacitance as a function of relative humidity.



Leaf Sensor Alerts When Plants Are Thirsty



http://www.youtube.com/watch?v=VM4X_fqPPco

Light-to-voltage Optical Sensors

- ▶ Click the [online document](#)
- ▶ Light-to-voltage optical sensors, each combining a **photodiode** and an amplifier (feedback resistor = 16 MW, 8 MW, and 2 MW respectively).
- ▶ The output voltage is directly proportional to the light intensity on the photodiode.

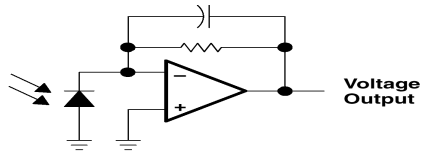

CdS Photoconductive Photocells

- ▶ Click the [online document](#)
- ▶ Cadmium Sulfoselenide (CdS)
- ▶ Light sensing using CdS

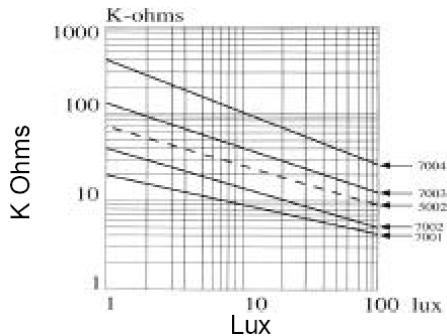

3-4. Hall effect Sensors

- ▶ voltage difference across an electrical conductor, transverse to an electric current
- ▶ A wheel containing two magnets passing by a [Hall effect sensor](#)

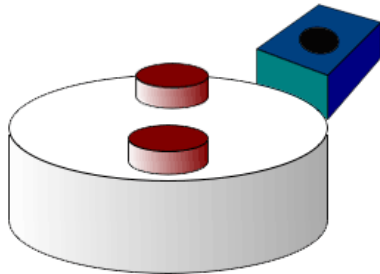

Application on Magnetic levitation



Magnetic levitation Train Model: http://www.youtube.com/watch?v=TeS_U9qFg7Y

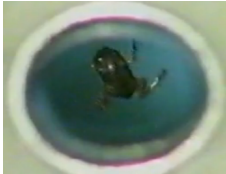

frog levitation

<http://www.youtube.com/watch?v=AlvyB-05i6E>



<http://www.youtube.com/watch?v=XjjBqzilKic>



Hall effect sensors and brushless DC motors

Brushless DC motor

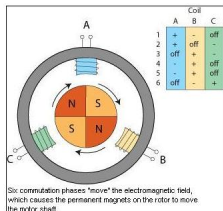

<https://www.youtube.com/watch?v=bCEiOnuODac>

Is it using Hall effect sensor? Don't know.



<http://www.youtube.com/watch?v=cm0h2Qf3upQ>

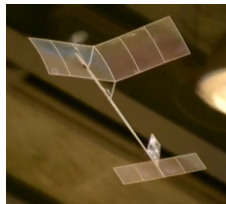

<http://www.youtube.com/watch?v=JmRkxZT4xhY>



3-5. Kinect Sensors



<https://learn.adafruit.com/hacking-the-kinect>



<https://www.youtube.com/watch?v=p2qlHoxPiOM>

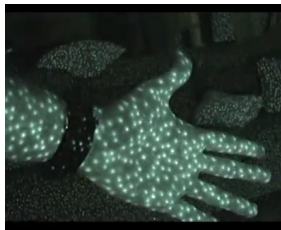

<http://www.youtube.com/watch?v=nvvQJxgykU>

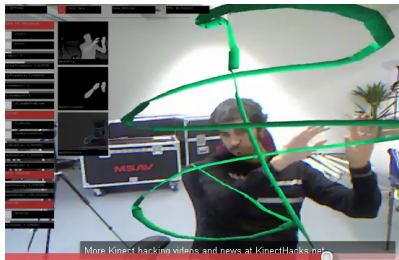

<http://www.youtube.com/watch?v=Brpu30vjCa4&feature=related>



Summary

- ▶ Studied the characteristics of various sensors
- ▶ and their applications

